

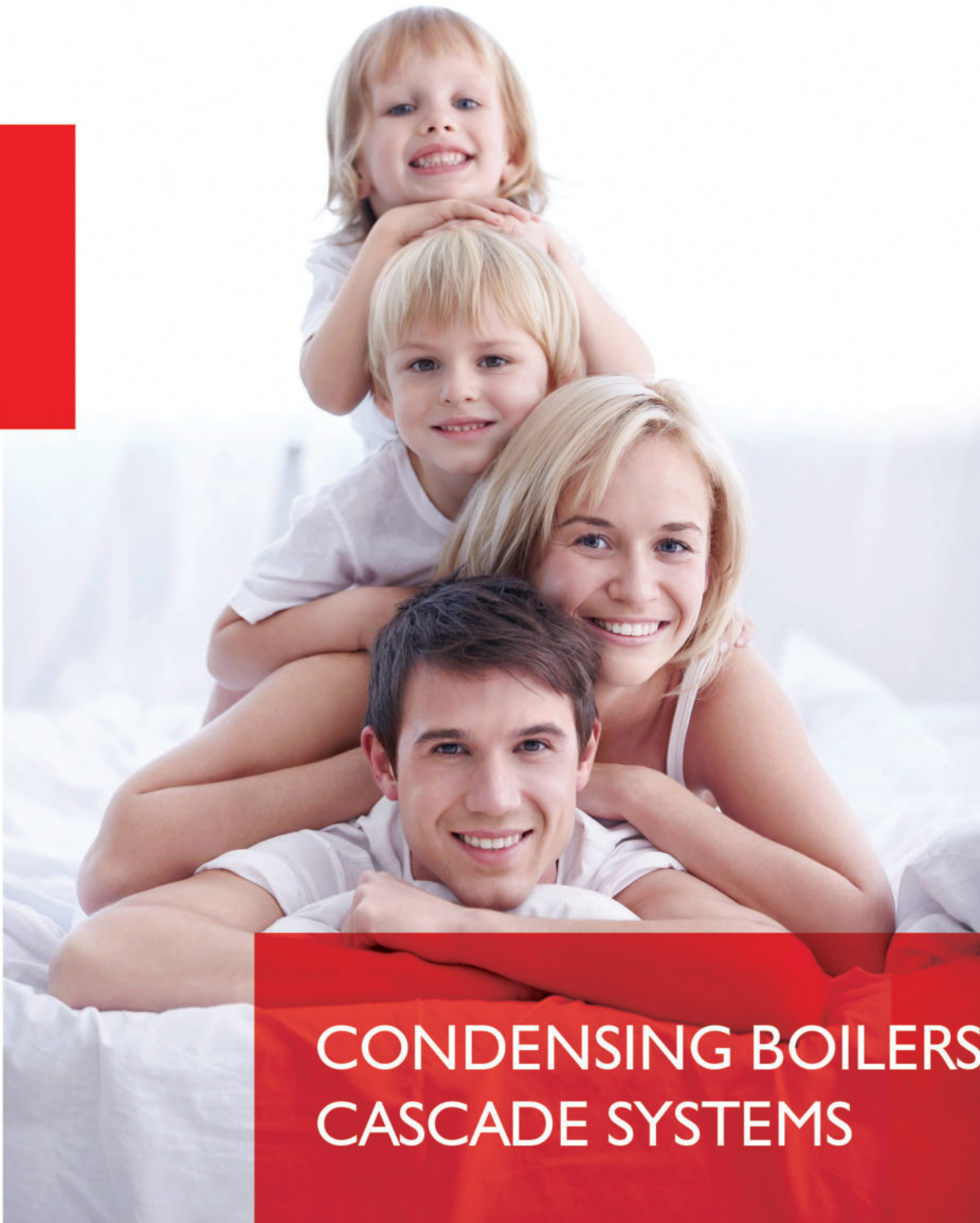

[www.ecodenseboilers.com](http://www.ecodenseboilers.com)

**ecodense**<sup>®</sup>  
CONDENSING BOILER



**CONDENSING BOILERS and  
CASCADE SYSTEMS**

ecodense<sup>®</sup>  
CONDENSING BOILER



04  
26



27  
36



37



# Ecodense Condensing Boilers

**ECODENSE** condensing boilers provide high-efficiency energy generation with their **"Premix Technology"** and **"Condensing Technology"**. Providing a space advantage in boiler room planning and conversions for individual and central heating boilers with its compact structure, **ECODENSE** condensing boilers, when used as CASCADE, meet high-capacity energy requirements with line-up operation and also expand the life-cycle of boilers by ensuring equal aging in boilers.

WALL HUNG TYPE

WT SERIES



(65 - 150 kW)

WT-S SERIES



(45 - 145 kW)

WT-S ONE SERIES



(35 - 65 kW)

WT-S DHW SERIES



(45 - 65 kW)

FLOOR TYPE

FTC -X SERIES



(200 - 760 kW)

FTC -MG SERIES



(800 - 3000 kW)

FT-S SERIES



(315 - 1060 kW)

ROOF TOP



(65 - 300 kW)

FLUE APPLICATIONS

40

OPTIONAL ACCESSORIES

43

CIRCUIT COMPONENTS

44



## CONDENSING TECHNOLOGY

At the end of the combustion process, a large proportion of heat is released outside along with waste gases. The Condensing technology does not allow releasing of this heat; provides higher energy saving. In the heat Boiler Return, the heat of water is drawn and sent to the heating system. When compared with the classic combustion system, the ratio of benefiting from latent heat of the fuel used with the Condensing technology reaches the maximum level, providing thermal efficiency of more than 100%.

## CASCADE SYSTEM





In these systems, multiple devices that are connected to each other engage/disengage as needed. In the Cascade system, all devices operate as modulation-controlled. In order to ensure simultaneous control of all boilers, they must be connected to the control unit.

With **ECODENSE** condensing boilers, it is possible to control up to 16 boilers as **CASCADE**. If any one of the boilers operating redundantly fails, the next boiler connected serially engages automatically and no problem is experienced in the order of operation. Thus, serviceability and maintainability of these boilers are ensured.

## PREMIX TECHNOLOGY

Mixing of gas and air required for combustion in order to achieve high-efficiency combustion before they arrive to burner is called as "**Premix Technology**". By a frequency-controlled fan, it is possible to provide ideal air content required for combustion at each capacity during high modulating operation.

## BOILER SAFETY









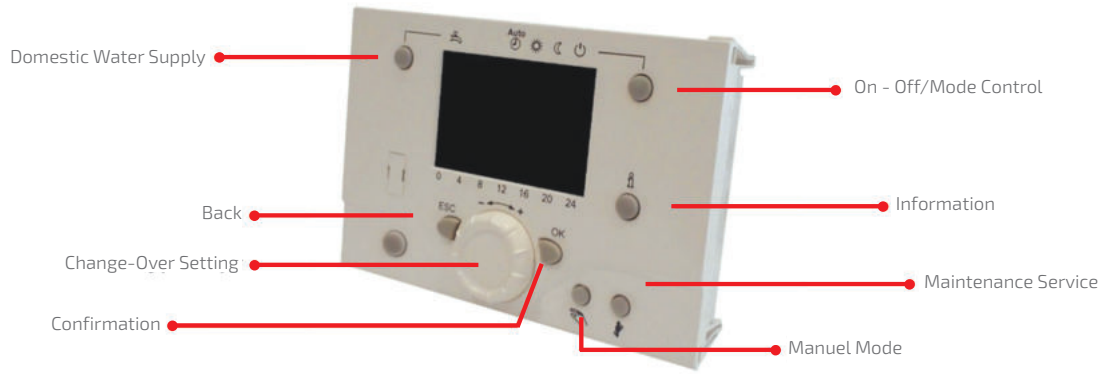



-  When outdoor temperature goes below +4 °C, the boiler automatically protects itself and prevents freezing.
-  The boiler protects itself, when the temperature of flue gas exceeds the set value during operation;
-  The boiler protects itself during unexpected high temperatures with combustion space safety thermostat.
-  It saves from consumption of gas, water and electricity thanks to low energy consumption levels.

\*\* Our appliances comply with the Regulation 2016/426/AB on appliances burning gaseous fuels, EN-15502-1+A1:2015 standards and ErP energy productivity regulations.

# CONTROL PANEL FEATURES











AVAILABLE FOR WT, WT-S, FTC-X, FTC-MG, FTS, ROOF TOP SERIES



 <p>Desired language from the languages defined in the Control Panel may be selected for system control.</p>	 <p>Heating circuits operate in 3 different temperature values: Appliance comfort mode temperature, Economy temperature and freezing mode temperature</p>	 <p>You can control the system using weekly timing program and save energy when you run it in economy mode.</p>	 <p>You can switch to vacation mode for the heating circuit via the Control Panel during your vacation.</p>	 <p>Heating curve can be adjusted depending on climate conditions.</p>	 <p>Adjustable minimum and maximum water temperature for floor heating systems.</p>
 <p>The last 20 errors in the control device can be viewed using the relevant parameter.</p>	 <p>It is compatible to run with solar power.</p>	 <p>Additional modules, instant water heater, return water temperature, heating circuit control can be added to the Control Panel.</p>	 <p>Cascade module can allow the system to operate as cascade. For wall mounted boilers, 16 boilers, including 1 master and 15 slave boilers, can be controlled as cascade.</p>	 <p>Special operating menu ensures measurement of the boiler operating times.</p>	 <p>The servicing icon shows that it is time for maintenance and allows tracking the time passed from the last maintenance.</p>

## AVAILABLE FOR WT-S ONE, WT-S DHW SERIES



 <p>Easy visibility of water pressure of the installation on digital screen via LCD screen and digital Control Panel</p>	 <p>Consists of control system, automatic ignition system and comfortable boiler control</p>	 <p>On / Off Reset Summer / Winter Mode</p>	 <p>Operable in summer and winter mode</p>	 <p>Ability to work and control in synchronization with Android and IOS operating systems</p>	 <p>Ability to operate according to different hydraulic configurations</p>
 <p>Easy inlet connections of combined ignition ionization electrodes</p>	 <p>With the simple parameter menu and troubleshooting system, it switches to failure mode and is locked depending on the state of flame</p>	 <p>Full protection against freezing of heating and domestic water in low ambient temperatures</p>	 <p>External room thermostat and OpenTherm applications provide maximum comfort</p>	 <p>Low fuel consumption and fixed combustion efficiency thanks to PWM driver high modulating fan and high modulating gas valve</p>	

 Ability to operate according to different heat demand with the variable flow pump control

 Anti-blockage System: Circulation pump is activated automatically once in 24 hours and prevent blockage.

# WT SERIES

## WALL HUNG TYPE CONDENSING BOILER

### FEATURES

- ∞ High efficiency with Condensing technology and Premix burner with micro-flame metal fiber coated steel flame tube,
- ∞ 8 different thermal capacity options (65, 80, 90,100,110,115,125 and 150 kW) in WT series aluminum-alloy individual boilers with Heat Exchanger and spiral fin, Wide capacity range up to 2400 kW in CASCADE systems,
- ∞ When used as CASCADE, it allows control of 16 boilers + 1 outdoor sensor + 1 mixed valve with the Control Panel on the boiler,
- ∞ **New!** Maximum air and water permeability with hermetic casing,
- ∞ **New!** Increased combustion safety with Back Current Damper,
- ∞ Energy saving through 5:1 modulating operation,
- ∞ Allows simple control with easy-to-use illuminated LCD panel; and viewing error codes and boiler information from one single panel,
- ∞ Allows programming of daily and weekly operation schedule,
- ∞ Allows seasonal heating program during summer and winter times,
- ∞ Ability to operate with Natural Gas and LPG,
- ∞ Allows operation in lower sound volumes,



109% Thermal efficient, aluminum-alloy, spiral fine Heat Exchanger

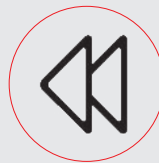

Internal Back Current Damper



Hermetic flue connection with impermeable casing

### AREAS OF USE



House/Residence



Hotels



Hospitals



Schools



Plazas / Shopping Malls



Gyms



Swimming Pools

## ECODENSE **WT** SERIES WALL-TYPE CONDENSING BOILER

TECHNICAL SPECIFICATIONS	UNIT	WT 65	WT 80	WT 90	WT 100	WT 110	WT 115	WT 125	WT 150
<b>Thermal Capacity</b>									
Maximum Heating Capacity	kW	65	80	88	100	110	115	125	150
Minimum Heating Capacity	kW	20	20	22	25	25	25	25	25
Maximum Heat Discharge for Heating (80°C / 60°C)	kW	63,4	76,4	88	98	108,5	112,7	122,5	138
Minimum Heat Discharge for Heating (80°C / 60°C)	kW	13,7	16	17	17,6	19	19	19,1	19,5
Maximum Heat Output for Heating (50°C / 30°C)	kW	69	85,6	98,5	105	114,9	121	131	151
Minimum Heat Output for Heating (50°C / 30°C)	kW	15,1	17,6	18,5	19,5	21	21	21	21,5
<b>Thermal Efficiency</b>									
Efficiency @ Pmaks. (80°C / 60°C)	%	98%	95,5%	98%	98%	98%	98%	98%	98,1%
Efficiency @ Pmin. (80°C / 60°C)	%	98,1%	98,3%	98,4%	98,2%	98,7%	98,6%	98,4%	98,3%
Efficiency @ Pmaks. (50°C / 30°C)	%	106,5%	106,2%	106,4%	106,2%	106,8%	106,4%	106,2%	106,3%
Efficiency @ Pmin. (50°C / 30°C)	%	107,1%	107,2%	107%	107,4%	107,2%	107,3%	107,6%	107,8%
Efficiency @ 30% (30°C)	%	109%	109%	109%	109%	109%	109%	109%	109%
<b>Domestic Water Circuit</b>									
Temperature Setting Range with External Hot Water Storage Tank	°C	10-65	10-65	10-65	10-65	10-65	10-65	10-65	10-65
<b>Heating Circuit</b>									
Maximum Heating Water Temperature	°C	90	90	90	90	90	90	90	90
Water Volume	L	5	5	5	7	7	7	7	9
Maximum Heating Water Pressure	bar	6	6	6	6	6	6	6	6
Minimum Heating Water Pressure	bar	1	1	1	1	1	1	1	1
<b>Gas Properties</b>									
Gas Type	-	G20-G31	G20-G31	G20-G31	G20-G31	G20-G31	G20-G31	G20-G31	G20-G31
Gas Inlet Pressure (G20)	mbar	20	20	20	20	20	20	20	20
Gas Inlet Pressure (G31)	mbar	37	37	37	37	37	37	37	37
<b>Combustion Properties</b>									
Maximum Flue Gas Temperature (50°C / 30°C)	°C	42	42	42	43	45	45	45	45
Maximum Flue Gas Temperature (80°C / 60°C)	°C	65	65	65	65	65	65	65	65
<b>Electric Properties</b>									
Power Supply	V / Hz	230/50	230/50	230/50	230/50	230/50	230/50	230/50	230/50
Protection Class	IP	X5D	X5D	X5D	X5D	X5D	X5D	X5D	X5D
Energy Consumption	W	100	100	100	200	200	200	200	300
Fuse Current Value to be Used	A	6	6	6	6	6	6	6	6
<b>Installation Connection Properties</b>									
Gas Connection Pipe Diameter	inch	3/4"	3/4"	3/4"	3/4"	3/4"	3/4"	3/4"	3/4"
Heating Circuit Inlet and Outlet Piping Diameter	inch	1 1/2"	1 1/2"	1 1/2"	1 1/2"	1 1/2"	1 1/2"	1 1/2"	1 1/2"
<b>General Features</b>									
Net Weight	kg	50	50	50	70	70	70	70	80
Flue Diameter (Ø)	mm	80/125	80/125	80/125	80/125	80/125	80/125	80/125	80/125
NOx Emission Class (EN 15502-1+A1)		6	6	6	6	6	6	6	6

G 20 Natural Gas, G 31 LPG



## FLOW DIAGRAM

### CONNECTIONS

- A - Boiler Inlet
- B - Boiler Outlet
- C - Gas Inlet
- D - Condensate Outlet

### MAIN PARTS

- 1 - Al-Si-Mg Heat Exchanger
- 2 - Premix Flame Tube
- 3 - Fan
- 4 - Back Current Damper
- 5 - Venturi / Mixer
- 6 - Gas Valve
- 7 - Pressure Sensor
- 8 - Inlet / Outlet Temperature Sensor
- 9 - Flue Gas Sensor
- 10 - Limit Thermostat
- 11 - Ignition Transformer
- 12 - Ignition and Ionization Electrode
- 13 - Air Purger
- 14 - Condensate Trap

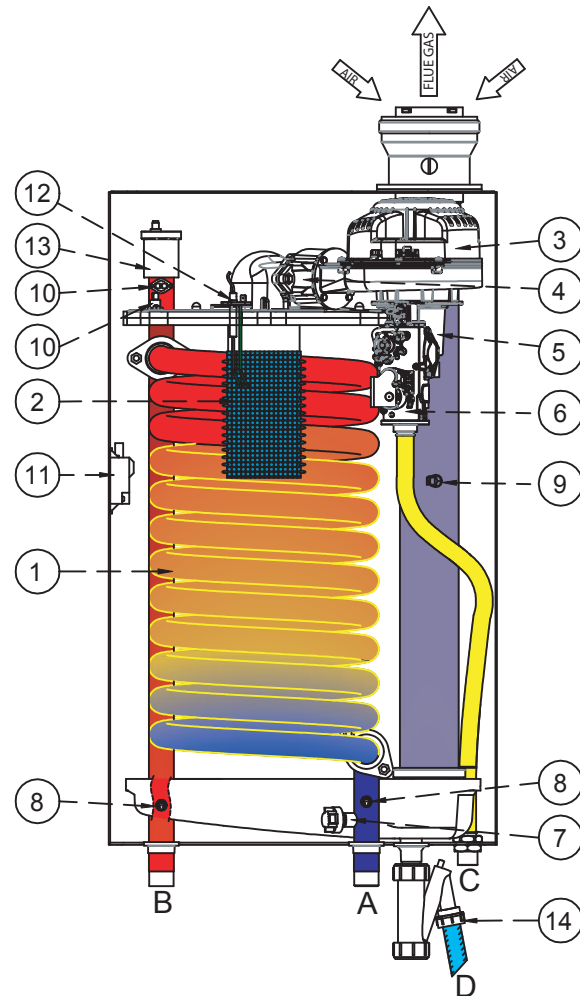

## OUTER DIMENSIONS & SIZES TABLE

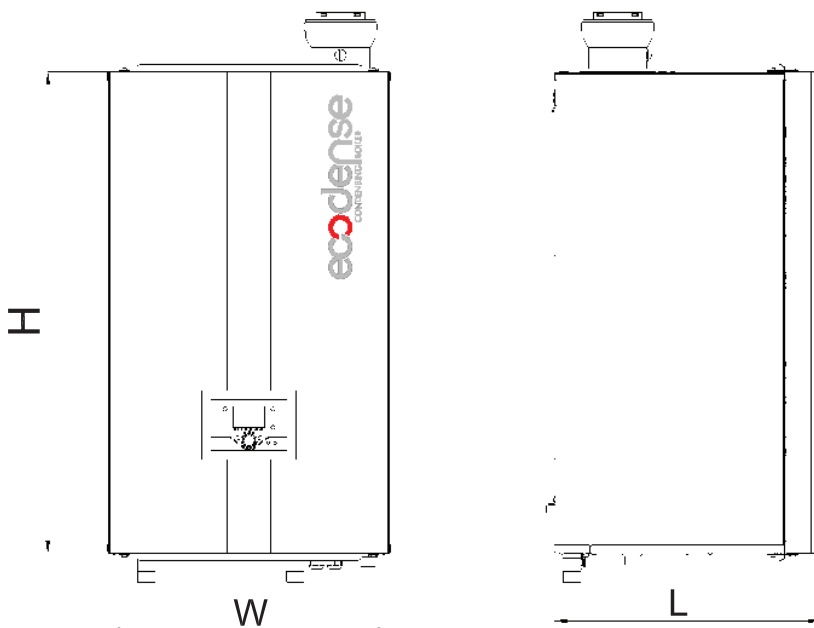

MODEL	W (mm)	H (mm)	L (mm)
WT-65	725	530	500
WT-80	725	530	500
WT-90	725	530	500
WT-100	725	530	500
WT-110	895	530	500
WT-115	895	530	500
WT-125	895	530	500
WT-150	950	540	500

# ECODENSE CONDENSING BOILER RADIATOR+ HOT WATER STORAGE TANK CIRCUIT DIAGRAM

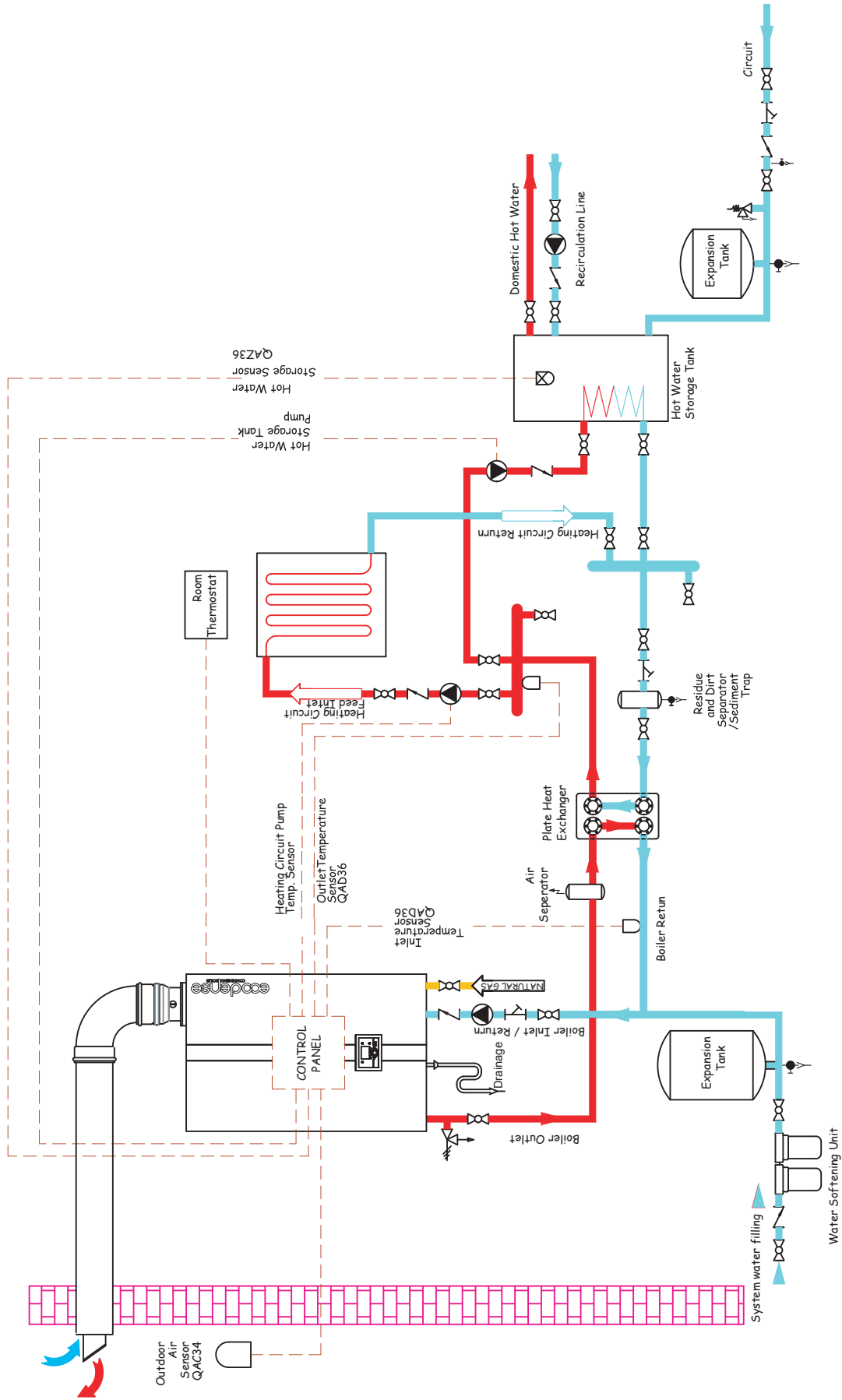

# ECODENSE CASCADE RADIATOR CIRCUIT DIAGRAM

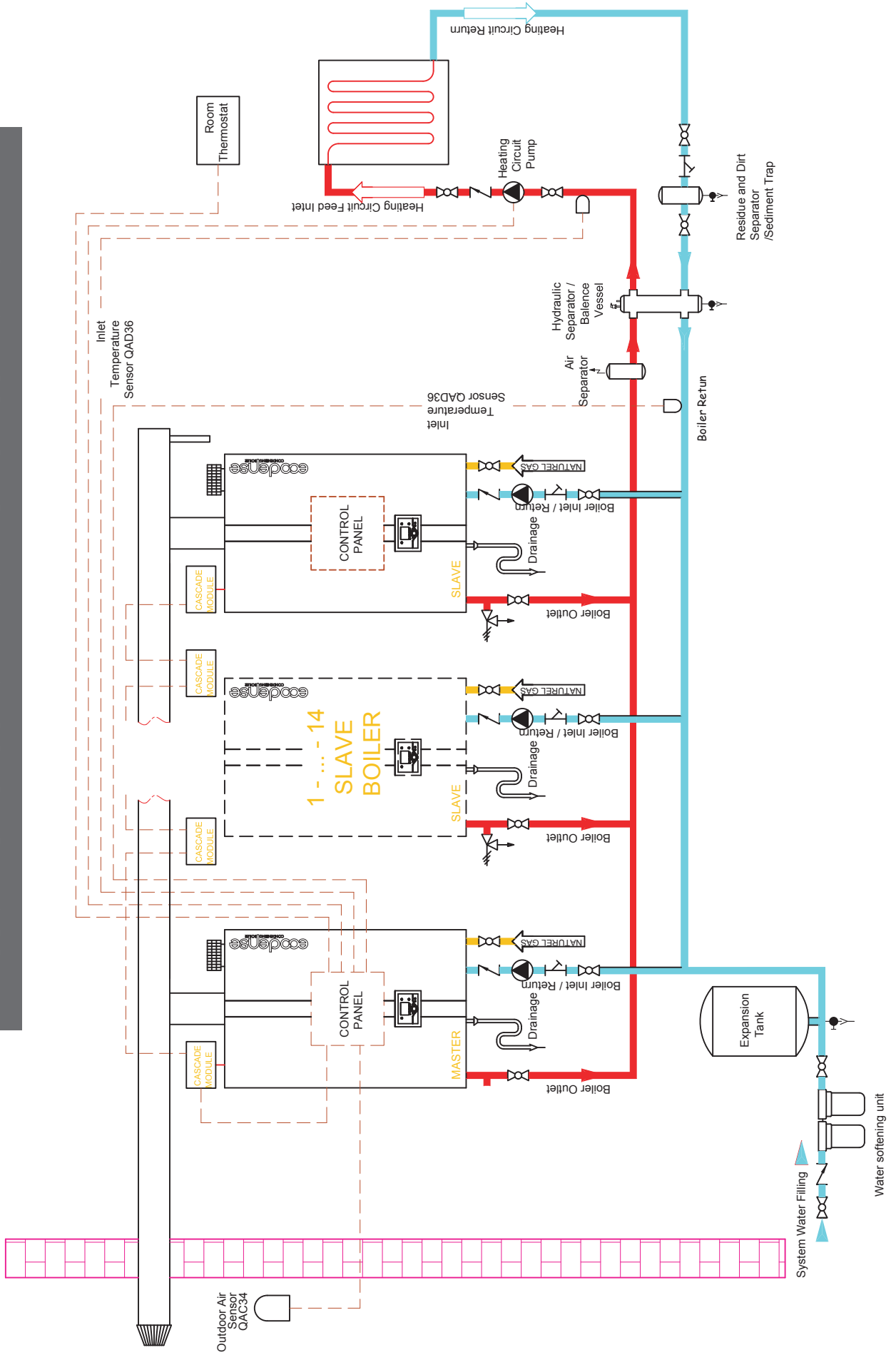

# WT-S SERIES

## WALL HUNG TYPE CONDENSING BOILER

### FEATURES

- ⌘ High efficiency with Condensing technology and Premix burner with micro-flame metal fiber coated steel flame tube,
- ⌘ 6 different thermal capacity options (45 kW, 55 kW, 65 kW, 100 kW, 120 kW and 145 kW) in WT-S series stainless steel individual boiler with Heat Exchanger , Wide thermal capacity range up to 2320 kW in CASCADE systems,
- ⌘ Low energy consumption with modulating primary circuit pump integrated to the boiler,
- ⌘ When used as CASCADE, it allows control of 16 boilers + 1 outdoor sensor + 1mixed valve with the Control Panel on the boiler,
- ⌘ Energy saving through 5:1 modulating operation,
- ⌘ Allows simple control with easy-to-use illuminated LCD panel; and viewing error codes and boiler information from one single panel,
- ⌘ Allows programming of daily and weekly operation schedule,
- ⌘ Allows seasonal heating program during summer and winter times,
- ⌘ Ability to operate with Natural Gas and LPG,
- ⌘ Allows operation in lower sound volumes,
- ⌘ Environmentally-friendly with lower NOx and CO emission



107% Thermal efficient  
Stainless steel Heat  
Exchanger



Modulating primary  
circuit pump integra-  
ted to the boiler



Hermetic flue connection  
with impermeable casing

### AREAS OF USE



House/Residence



Hotels



Hospitals



Schools



Plazas /  
Shoping Malls



Gyms



Swimming  
Pools

## ECODENSE **WT-S** SERIES WALL-TYPE CONDENSING BOILER

TECHNICAL SPECIFICATIONS	UNIT	WT-S 45	WT-S 55	WT-S 65	WT-S 100	WT-S 120	WT-S 145
<b>Thermal Capacity</b>							
Maximum Heating Capacity	kW	45	55	65	100	120	145
Minimum Heating Capacity	kW	11	12	13,5	14	15	17,5
Maximum Heat Discharge for Heating (80°C / 60°C)	kW	43,7	53,4	63,1	97	116,4	140,7
Minimum Heat Output for Heating (80°C / 60°C)	kW	12,3	13,1	13,7	15,2	16,8	18,2
Maximum Heat Discharge for Heating (50°C / 30°C)	kW	46,4	57,2	67,6	102,8	123,6	150,8
Minimum Heat Load (50°C / 30°C)	kW	12,9	13,9	14,6	15,8	17,3	19,2
<b>Efficiency</b>							
Efficiency @ Pmax. (80°C / 60°C)	%	97	97,5	97,4	97,4	97	97,2
Efficiency @ Pmin. (80°C / 60°C)	%	98,5	98,5	98	98,2	98,4	98,2
Efficiency @ Pmax. (50°C / 30°C)	%	105,2	105,3	105,4	105,6	105,3	105,6
Efficiency @ Pmin. (50°C / 30°C)	%	107,4	107,6	107,2	107,1	107,3	107,4
Efficiency @ 30% (30°C)	%	108,7	109	108,2	108,6	108,4	108,7
<b>Domestic Water Circuit</b>							
Temperature Setting Range with External Hot Water Storage Tank	°C	10-65	10-65	10-65	10-65	10-65	10-65
<b>Heating Circuit</b>							
Maximum Operating Temperature	°C	85	85	85	85	85	85
Maximum Operating Pressure	bar	4-6	4-6	4-6	4-6	4-6	4-6
Minimum Operating Pressure	bar	0,8	0,8	0,8	0,8	0,8	0,8
<b>Gas Properties</b>							
Gas Type	-	G20-G31	G20-G31	G20-G31	G20-G31	G20-G31	G20-G31
Gas Inlet Pressure (G20)	mbar	20	20	20	20	20	20
Gas Inlet Pressure (G31)	mbar	37	37	37	37	37	37
<b>Combustion Values</b>							
Maximum Flue Gas Outlet Temperature (50°C / 30°C)	°C	42	42	42	45	45	45
Maximum Flue Gas Outlet Temperature (80°C / 60°C)	°C	65	65	65	65	65	65
NOx Emission Class (EN 15502-1+A1)	-	5	5	5	5	5	5
<b>Electrical Values</b>							
Voltage & Frequency	V / Hz	230/50	230/50	230/50	230/50	230/50	230/50
Energy Consumption	W	150	190	190	300	300	300
Fuse Current Value to be Used	A	6	6	6	6	6	6
<b>Hydraulic circuit properties</b>							
Gas Connection	inch	1/2"	1/2"	1/2"	1/2"	1/2"	1/2"
Heating Circuit Inlet and Outlet Piping Diameter	inch	1"	1"	1"	1"	1"	1"
<b>General Features</b>							
Net Weight	kg	45	47	50	53	58	61
Flue Diameter (Ø)	mm	80/125	80/125	80/125	80/125	80/125	80/125
G 20 Natural Gas, G 31 LPG							

## FLOW DIAGRAM

WT-S 45 - 55 - 65

### CONNECTIONS

- A - Boiler Inlet
- B - Boiler Outlet
- C - Gas Inlet
- D - Condensate Outlet

### MAIN PARTS

- 1 - Stainless Steel Heat Exchanger
- 2 - Circulation Pump
- 3 - Fan
- 4 - Venturi / Mixer
- 5 - Gas Valve
- 6 - Silencer
- 7 - Inlet / Outlet Temperature Sensor
- 8 - Limit Thermostat
- 9 - Pressure Sensor
- 10- Flue Gas Sensor
- 11- Ignition Transformer
- 12- Ignition and Ionization Electrode
- 13- Air Purger
- 14- Condensate Trap
- 15- Collector

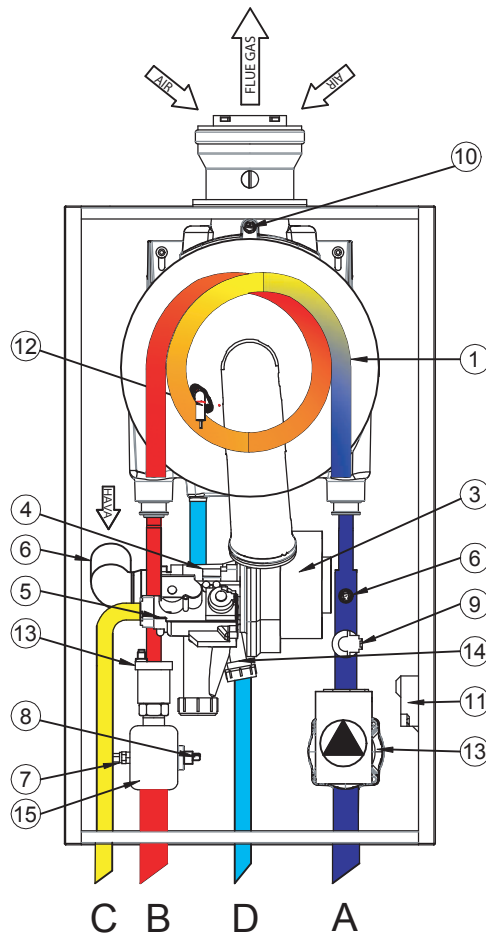

## FLOW DIAGRAM

WT-S 100 - 120 - 145

### CONNECTIONS

- A - Boiler Inlet
- B - Gas Inlet
- C - Boiler Outlet
- D - Condensate Outlet

### MAIN PARTS

- 1 - Bluejet Premix Burner
- 2 - Fan
- 3 - Venturi (Mixer)
- 4 - Gas Valve
- 5 - Ignition Transformer
- 6 - Air Purger
- 7 - Return Water Sensor
- 8 - Feed Water Sensor
- 9 - Pressure Sensor
- 10- Condensate Trap
- 11- Flue Gas Temperature Sensor
- 12- Ignition Electrode
- 13- Ionization Electrode

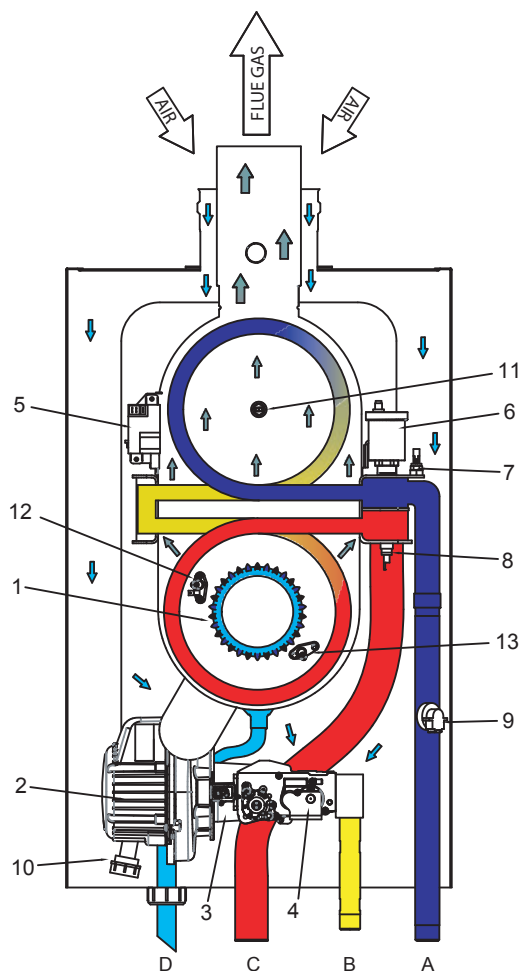

## OUTER DIMENSIONS & SIZES TABLE

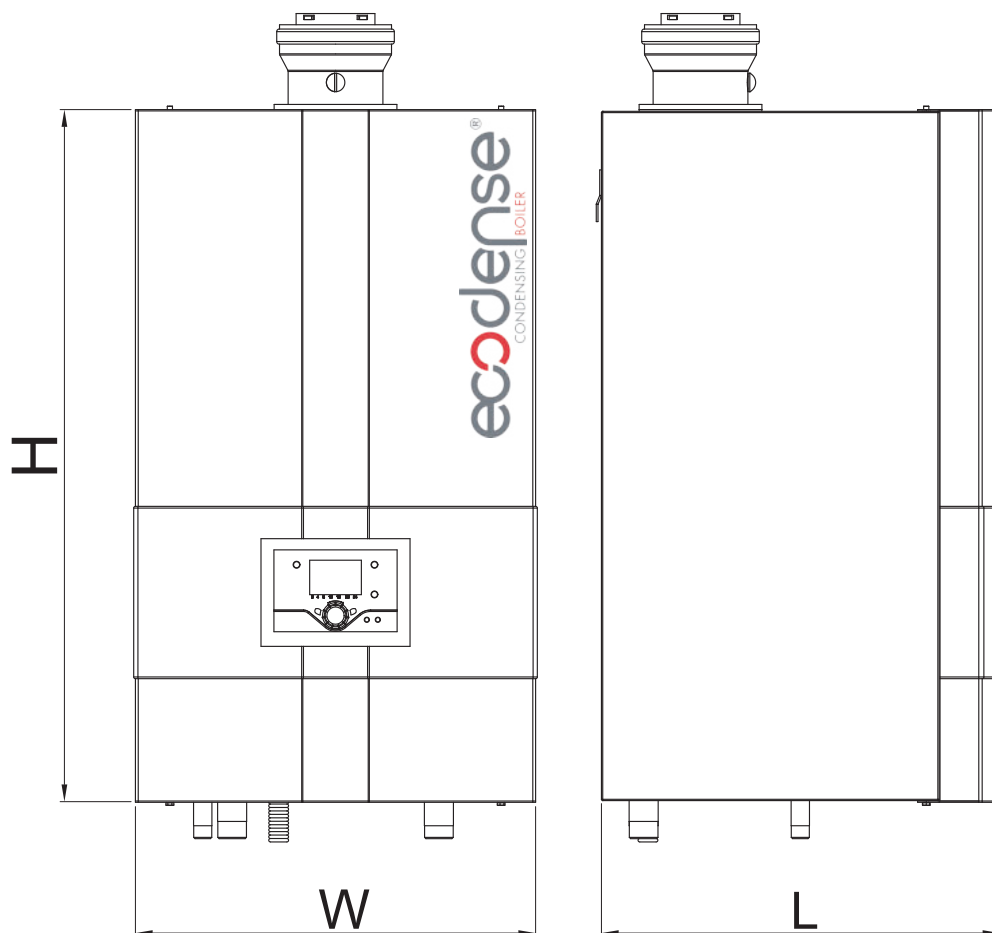

MODEL	W (mm)	H (mm)	L (mm)
WT-S 45	465	800	465
WT-S 55	465	800	465
WT-S 65	465	800	465
WT-S 100	465	1050	615
WT-S 120	465	1050	615
WT-S 145	465	1050	615

# ECODENSE CONDENSING BOILER WT-S CASCADE RADIATOR CIRCUIT DIAGRAM

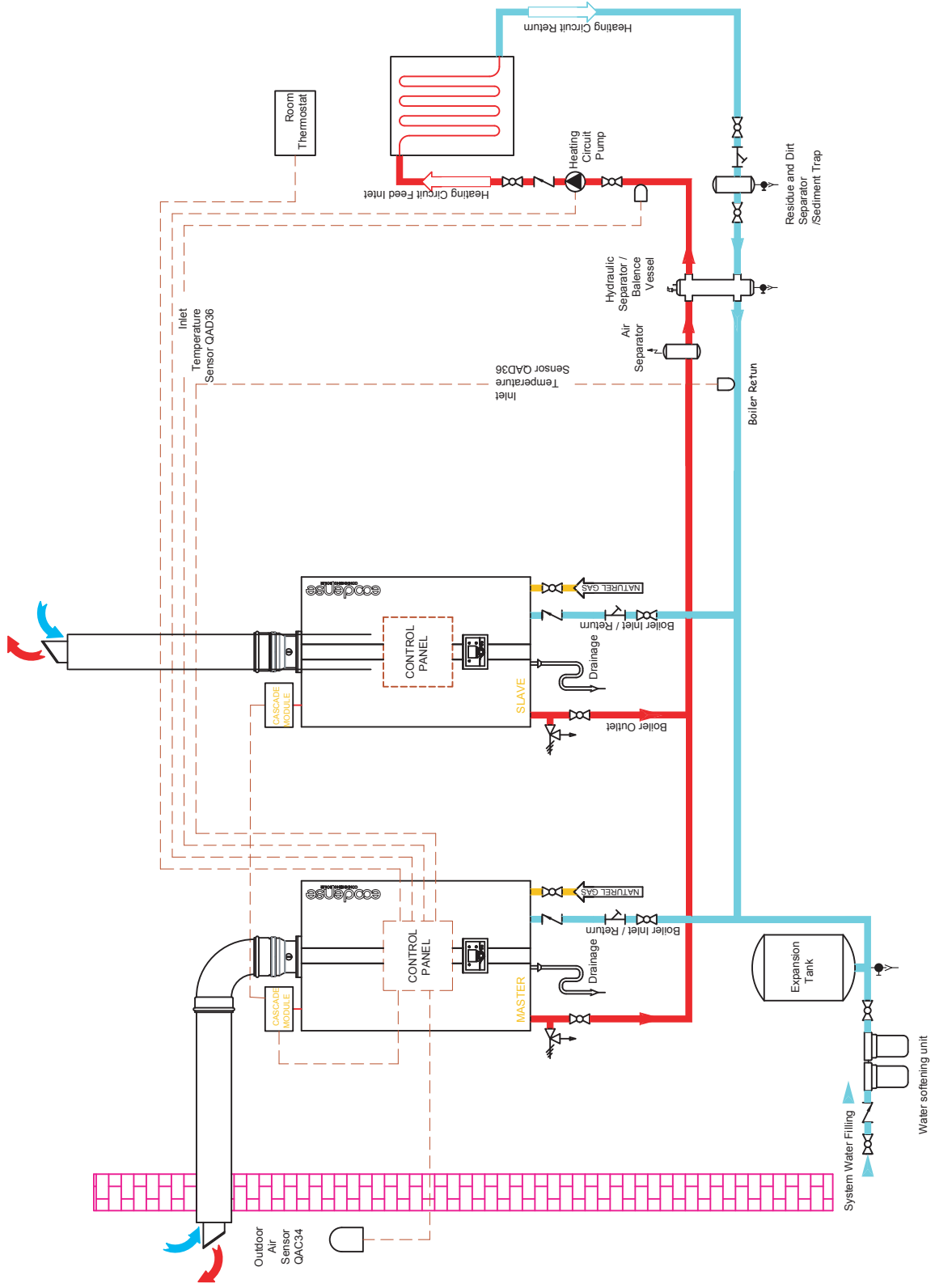



# WT-S ONE OH, OH+EX ve BS SERIES

WALL-TYPE CONDENSING BOILER WITH STAINLESS STEEL HEAT EXCHANGER



**OH SERIES:**  
HEATING ONLY  
WALL HUNG TYPE  
CONDENSING  
BOILER



**OH+EX SERIES:**  
HEATING ONLY  
INTERNAL EXPANSION  
TANK WALL-TYPE  
CONDENSING BOILER



**BS SERIES:**  
HOT WATER STORAGE  
TANK-SUPPORTED  
WALL HUNG TYPE  
CONDENSING BOILER



## FEATURES

- High efficiency with Condensing technology and Premix burner with micro-flame metal fiber coated steel flame tube,
- 4 different thermal capacity options (35 kW, 45 kW, 55 kW, 65 kW) in WT-S ONE OH and BS Series boilers and 2 different thermal capacity options (35 kW, 45 kW) in WT-S ONE OH + EX Series boilers with stainless steel Heat Exchanger,
- Optional external domestic water storage tank for use with WT-S ONE BS series,
- Internal expansion tank option for use with WT-S ONE OH+EX series,
- Low energy consumption with modulating primary circuit pump integrated to the boiler,
- Energy saving through 5:1 modulating operation, Allows simple control with easy-to-use illuminated LCD panel; and viewing error codes and boiler information from this panel,
- Ability to operate with Natural Gas and LPG,
- Operation in low noise levels thanks to its body configuration with high heat and sound isolation,
- Superior safety features:
  - Flame safety control; ionization,
  - Flue gas temperature control,
  - Heating circuit overheating safety,
  - Frost protection,
  - Low water pressure safety,
- Optional room thermostat connection,
- Optional remote control,
- Environmentally-friendly with lower NOx and CO emission rates.



107% Thermal efficient  
Stainless steel Heat  
Exchanger



Modulating primary  
circuit pump integra-  
ted to the boiler



Internal Expansion  
Tank



Hot water with  
internal 3-way  
valve

## AREAS OF USE



House/Residence



Hotels



Hospitals



Schools



Plazas /  
Shoping Malls



Gyms



Swimming  
Pools

## ECODENSE **WT - S ONE OH** SERIES WALL-TYPE CONDENSING BOILER

TECHNICAL SPECIFICATIONS	UNIT	WT-S ONE 35 OH	WT-S ONE 45 OH	WT-S ONE 55 OH	WT-S ONE 65 OH
<b>Thermal Capacity</b>					
Maximum Heating Capacity	kW	35	45	55	65
Minimum Heating Capacity	kW	7	8	10	12
Maximum Heat Discharge for Heating (80°C / 60°C)	kW	34,3	43,4	54,1	63,8
Minimum Heat Output for Heating (80°C / 60°C)	kW	6,9	7,6	9,5	11
Maximum Heat Output for Heating (50°C / 30°C)	kW	36,9	45,9	56,1	68,1
Minimum Heat Output for Heating (50°C / 30°C)	kW	7,3	8,1	10,3	11,7
<b>Thermal Efficiency</b>					
Efficiency @ Pmaks. (80°C / 60°C)	%	97,4%	97,3%	97,5%	97,4%
Efficiency @ Pmin. (80°C / 60°C)	%	98,6%	99%	99,1%	99,2%
Efficiency @ Pmaks. (50°C / 30°C)	%	105,1%	105%	105%	105,2%
Efficiency @ Pmin. (50°C / 30°C)	%	107%	107%	107%	107,3%
Efficiency @ 30% (30°C)	%	109%	109%	109%	109%
<b>Heating Circuit</b>					
Maximum Heating Water Temperature	°C	85	85	85	85
Maximum Heating Water Pressure	bar	3	3	3	3
Minimum Heating Water Pressure	bar	0,8	0,8	0,8	0,8
<b>Gas Properties</b>					
Gas Type	-	G20-G31	G20-G31	G20-G31	G20-G31
Gas Inlet Pressure (G20)	mbar	20	20	20	20
Gas Inlet Pressure (G31)	mbar	37	37	37	37
<b>Combustion Properties</b>					
Maximum Flue Gas Temperature (50°C / 30°C)	°C	40	42	43	45
Maximum Flue Gas Temperature (80°C / 60°C)	°C	65	65	65	65
<b>Electrical Characteristics</b>					
Power Supply	V / Hz	230/50	230/50	230/50	230/50
Protection Class	IP	X4D	X4D	X4D	X4D
<b>Installation Connection Properties</b>					
Gas Connection Pipe Diameter	inch	3/4"	3/4"	3/4"	3/4"
Heating Circuit Inlet and Outlet Piping Diameter	inch	3/4"	3/4"	1"	1"
<b>General Features Connection Properties</b>					
Net Weight	kg	47	50	58	61
Flue Diameter (Ø)	mm	60/100	60/100	80/125	80/125
NOx Emission Class (EN 15502-1+A1)	-	6	6	6	6
G 20 Natural Gas, G 31 LPG					

## ECODENSE WT - S ONE OH EX SERIES WALL-TYPE CONDENSING BOILER

TECHNICAL SPECIFICATIONS	UNIT	WT-S ONE 35 OH-EX	WT-S ONE 45 OH-EX
<b>Thermal Capacity</b>			
Maximum Heating Capacity	kW	35	45
Minimum Heating Capacity	kW	7	8,5
Maximum Heat Discharge for Heating (80°C / 60°C)	kW	34,2	43,2
Minimum Heat Output for Heating (80°C / 60°C)	kW	7,1	7,9
Maximum Heat Output for Heating (50°C / 30°C)	kW	36,7	45,5
Minimum Heat Output for Heating (50°C / 30°C)	kW	7,2	8,2
<b>Thermal Efficiency</b>			
Efficiency @ Pmaks. (80°C / 60°C)	%	97,4%	97,3%
Efficiency @ Pmin. (80°C / 60°C)	%	98,6%	99%
Efficiency @ Pmaks. (50°C / 30°C)	%	105,1%	105%
Efficiency @ Pmin. (50°C / 30°C)	%	107%	107%
Efficiency @ 30% (30°C)	%	109%	109%
<b>Heating Circuit</b>			
Maximum Heating Water Temperature	°C	85	85
Maximum Heating Water Pressure	bar	3	3
Minimum Heating Water Pressure	bar	0,8	0,8
<b>Gas Properties</b>			
Gas Type	-	G20-G31	G20-G31
Gas Inlet Pressure (G20)	mbar	20	20
Gas Inlet Pressure (G31)	mbar	37	37
<b>Combustion Properties</b>			
Maximum Flue Gas Temperature (50°C / 30°C)	°C	40	42
Maximum Flue Gas Temperature (80°C / 60°C)	°C	65	65
<b>Electrical Characteristics</b>			
Power Supply	V / Hz	230/50	230/50
Protection Class	IP	X4D	X4D
<b>Installation Connection Properties</b>			
Expansion Tank Capacity	L	12	12
Gas Connection Pipe Diameter	inch	3/4"	3/4"
Heating Circuit Inlet and Outlet Piping Diameter	inch	3/4"	3/4"
<b>General Features</b>			
Net Weight	kg	50	53
Flue Diameter (Ø)	mm	60/100	60/100
NOx Emission Class (EN 15502-1+A1)	-	6	6
G 20 Natural Gas, G 31 LP			

## ECODENSE WT - S ONE BS SERIES WALL-TYPE CONDENSING BOILER

TECHNICAL SPECIFICATIONS	UNIT	WT-S ONE 35 BS	WT-S ONE 45 BS	WT-S ONE 55 BS	WT-S ONE 65 BS
<b>Thermal Capacity</b>					
Maximum Heating Capacity	kW	35	45	55	65
Minimum Heating Capacity	kW	7	8	10	11,5
Maximum Heat Discharge for Heating (80°C / 60°C)	kW	34,1	43,5	54,2	63,6
Minimum Heat Output for Heating (80°C / 60°C)	kW	6,7	7,4	9,6	10,8
Maximum Heat Output for Heating (50°C / 30°C)	kW	36,7	45,7	56,2	67,9
Minimum Heat Output for Heating (50°C / 30°C)	kW	7,2	7,7	10,2	11,4
Maximum Domestic Water Thermal Capacity (when external hot water storage tank is used)	kW	35,2	45,6	56,1	66,1
<b>Thermal Efficiency</b>					
Efficiency @ Pmaks. (80°C / 60°C)	%	97,2%	97,3%	97,5%	97,4%
Efficiency @ Pmin. (80°C / 60°C)	%	98,1%	98,2%	98,3%	98,4%
Efficiency @ Pmaks. (50°C / 30°C)	%	105%	105%	105%	105,7%
Efficiency @ Pmin. (50°C / 30°C)	%	107%	107%	107%	107,2%
Efficiency @ 30% (30°C)	%	109%	109%	109%	109%
<b>Domestic Water Circuit</b>					
Temperature Setting Range with External Hot Water Storage Tank	°C	10-65	10-65	10-65	10-65
<b>Heating Circuit</b>					
Maximum Heating Water Temperature	°C	85	85	85	85
Maximum Heating Water Pressure	bar	3	3	3	3
Minimum Heating Water Pressure	bar	0,8	0,8	0,8	0,8
<b>Gas Properties</b>					
Gas Type	-	G20-G31	G20-G31	G20-G31	G20-G31
Gas Inlet Pressure (G20)	mbar	20	20	20	20
Gas Inlet Pressure (G31)	mbar	37	37	37	37
<b>Combustion Properties</b>					
Maximum Flue Gas Temperature (50°C / 30°C)	°C	40	42	43	45
Maximum Flue Gas Temperature (80°C / 60°C)	°C	65	65	65	65
<b>Electrical Characteristics</b>					
Power Supply	V / Hz	230/50	230/50	230/50	230/50
Protection Class	IP	X4D	X4D	X4D	X4D
<b>Installation Connection Properties</b>					
Gas Connection Pipe Diameter	inch	3/4"	3/4"	3/4"	3/4"
Heating Circuit Inlet and Outlet Piping Diameter	inch	3/4"	3/4"	1"	1"
<b>General Features</b>					
Net Weight	kg	47	51	55	58
Flue Diameter (Ø)	mm	60/100	60/100	80/125	80/125
NOx Emission Class (EN 15502-1+A1)	-	6	6	6	6
G 20 Natural Gas, G 31 LP					

## FLOW DIAGRAMS

### WT-S ONE 35 - 45 OH

#### CONNECTIONS

- A - Boiler Inlet
- B - Boiler Outlet
- C - Gas Inlet
- D - Condensate Outlet

#### MAIN PARTS

- 1 - Stainless Steel Heat Exchanger
- 2 - Ignition and Ionization Electrode
- 3 - Pump with Automatic Air Purger
- 4 - Safety Valve
- 5 - Gas Valve
- 6 - Condensate Trap
- 7 - Modulating Fan
- 8 - Venturi / Mixer
- 9 - Heating Water Temperature Sensor
- 10 - Pressure Sensor
- 11 - Flue Gas Sensor

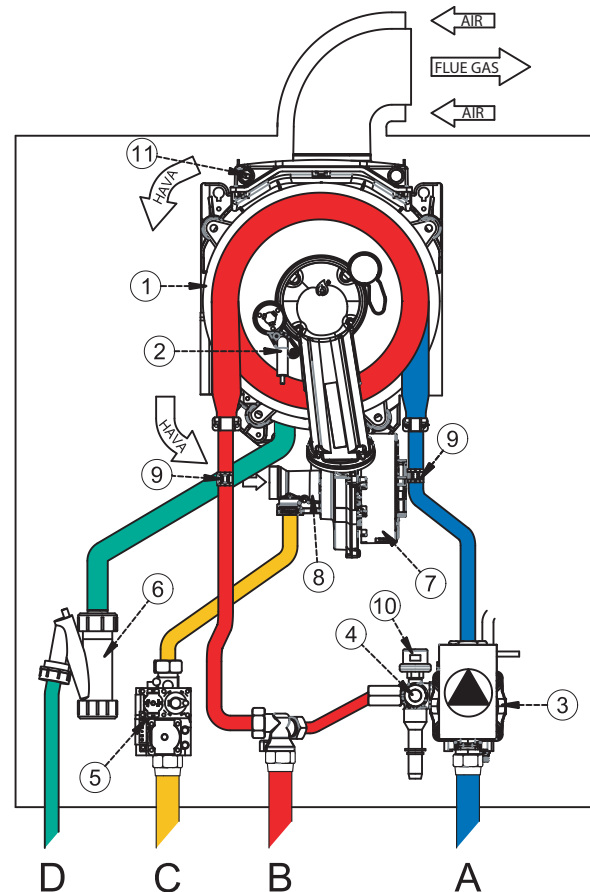

### WT-S ONE 55-65 OH

#### CONNECTIONS

- A - Boiler Inlet
- B - Boiler Outlet
- C - Gas Inlet
- D - Condensate Outlet

#### MAIN PARTS

- 1 - Stainless Steel Heat Exchanger
- 2 - Circulation Pump
- 3 - Modulating Fan
- 4 - Venturi / Mixer
- 5 - Gas Valve
- 6 - Silencer
- 7 - Collector
- 8 - Inlet / Outlet Temperature Sensor
- 9 - Pressure Sensor
- 10 - Flue Gas Sensor
- 11 - Ignition and Ionization Electrode
- 12 - Air Purger
- 13 - Condensate Trap

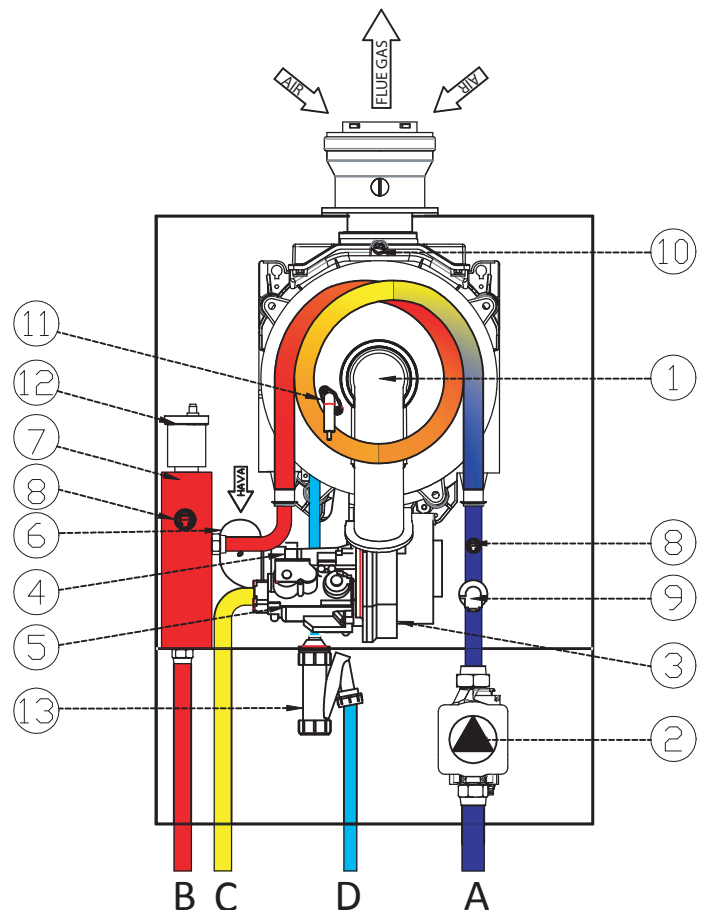

## WT-S ONE 35 - 45 OH +EX

### CONNECTIONS

- A - Boiler Inlet
- B - Boiler Outlet
- C - Gas Inlet
- D - Condensate Outlet

### MAIN PARTS

- 1 - Stainless Steel Heat Exchanger
- 2 - Ignition and Ionization Electrode
- 3 - Pump with Automatic Air Purger
- 4 - Safety Valve
- 5 - Gas Valve
- 6 - Condensate Trap
- 7 - Modulating Fan
- 8 - Venturi / Mixer
- 9 - Heating Water Temperature Sensor
- 10 - Pressure Sensor
- 11 - Expansion Tank
- 12 - Flue Gas Sensor

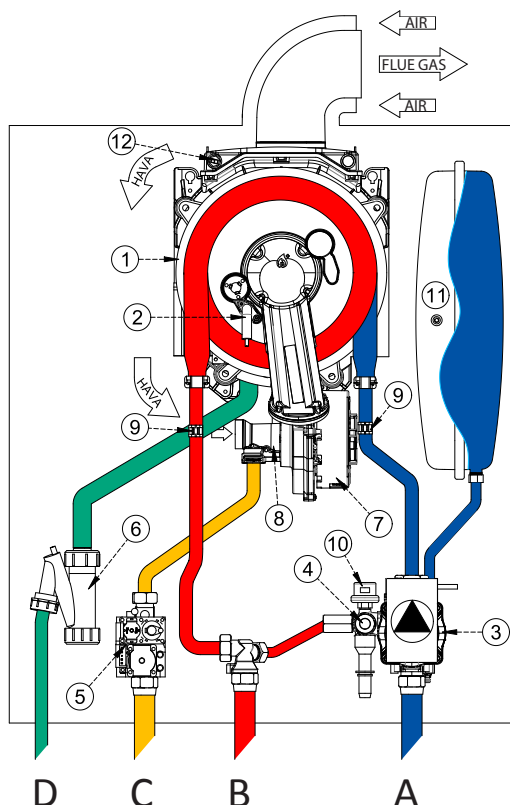

## WT-S ONE 35 - 45 BS

### CONNECTIONS

- A - Boiler Inlet
- B - Domestic Water Return
- C - Domestic Water Feed
- D - Boiler Outlet
- E - Gas Inlet
- F - Condensate Discharge

### MAIN PARTS

- 1 - Stainless Steel Heat Exchanger
- 2 - Ignition and Ionization Electrode
- 3 - Pump with Automatic Air Purger
- 4 - Safety Valve
- 5 - Gas Valve
- 6 - Condensate Trap
- 7 - Modulating Fan
- 8 - Venturi / Mixer
- 9 - Heating Water Temperature Sensor
- 10 - Pressure Sensor
- 11 - 3-way Valve
- 12 - 3-way Valve Servomotor
- 13 - Expansion Tank
- 14 - Flue Gas Sensor

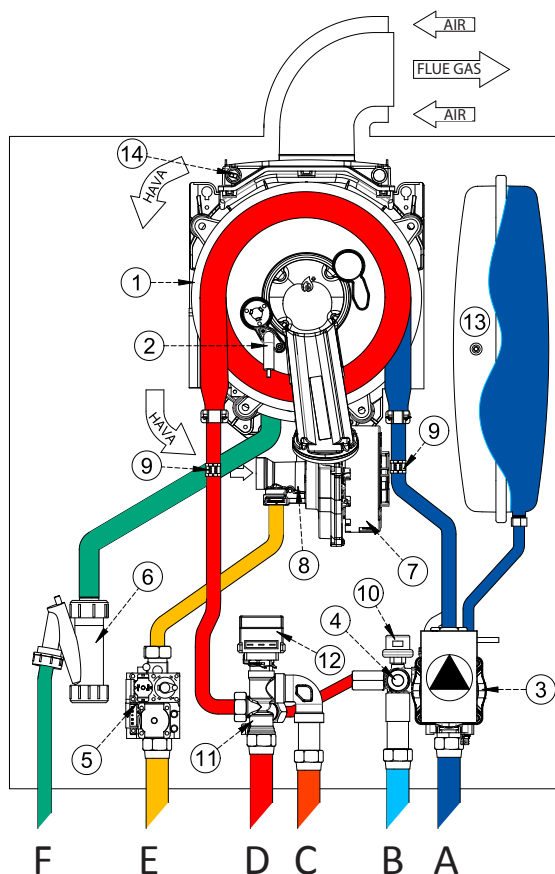

## WT-S ONE 55-65 BS

### CONNECTIONS

- A - Boiler Inlet
- B - Boiler Outlet
- C - Domestic Water Outlet
- D - Gas Inlet
- E - Condensate Outlet

### MAIN PARTS

- 1 - Stainless Steel Heat Exchanger
- 2 - Circulation Pump
- 3 - Fan
- 4 - Venturi / Mixer
- 5 - Gas Valve
- 6 - Silencer
- 7 - 3-way Valve and Motor
- 8 - Collector
- 9 - Inlet / Outlet Temperature Sensor
- 10 - Pressure Sensor
- 11 - Flue Gas Sensor
- 12 - Ignition and Ionization Electrode
- 13 - Air Purger
- 14 - Condensate Trap

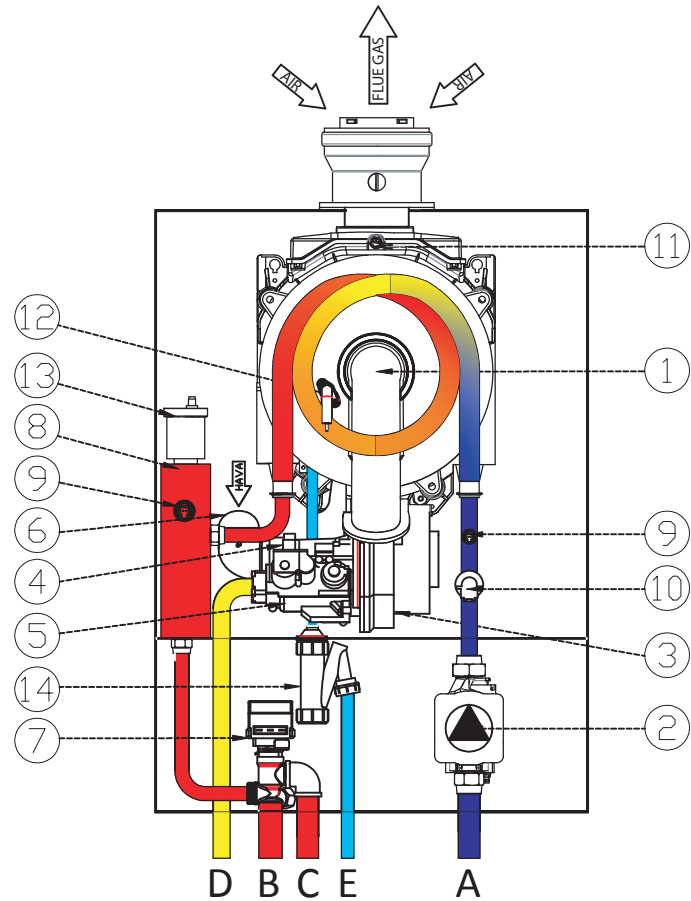

## OUTER DIMENSIONS & SIZES TABLE

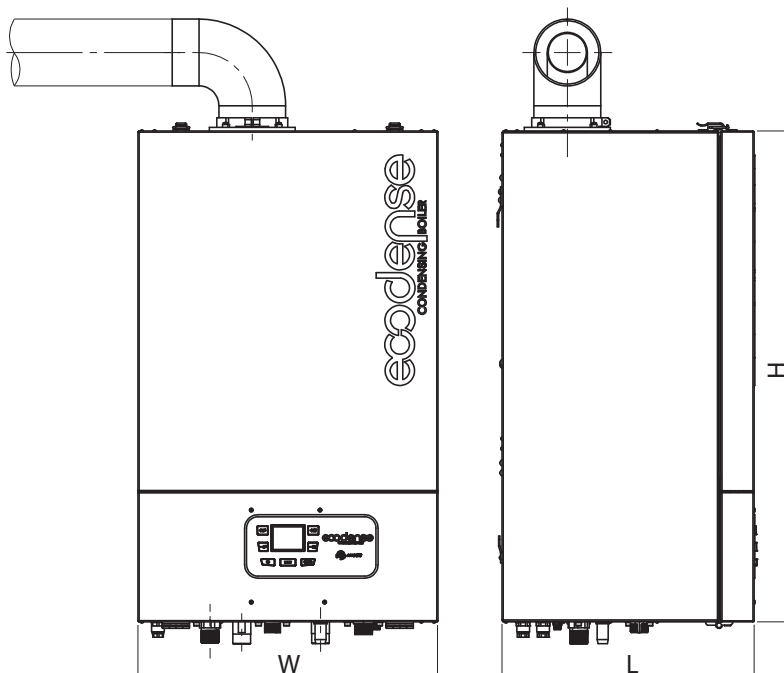

MODEL	W (mm)	H (mm)	L (mm)
WT-S ONE 35 OH	450	378	735
WT - S ONE 35 OH - EX	450	378	735
WT - S ONE 35 BS	450	378	735
WT - S ONE 45 OH	450	378	735
WT - S ONE 45 OH - EX	450	378	735
WT - S ONE 45 BS	450	378	735
WT - S ONE 55 OH	465	443	802
WT - S ONE 55 BS	465	443	802
WT - S ONE 65 OH	465	443	802
WT - S ONE 65 BS	465	443	802

## ECODENSE CONDENSATING BOILER WT-S ONE 35-45 - [OH] CIRCUIT DIAGRAM

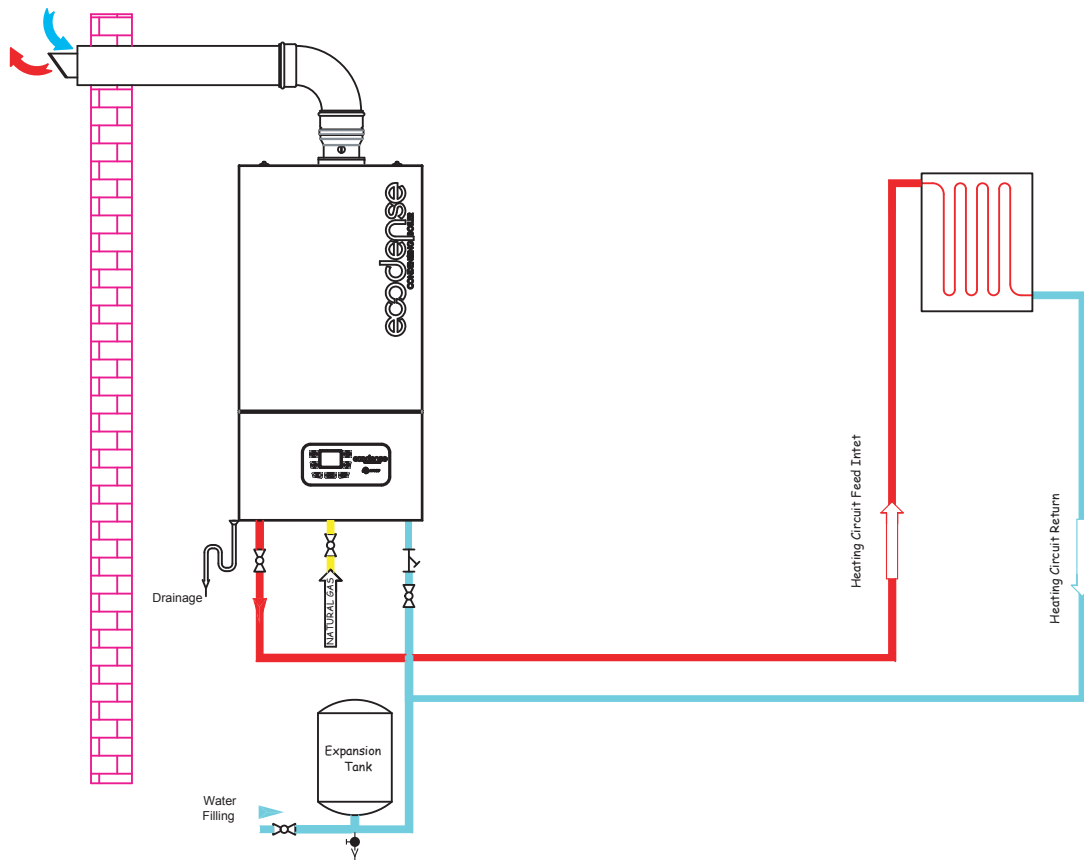

## ECODENSE CONDENSATING BOILER WT-S ONE 55-65 - [OH] CIRCUIT DIAGRAM

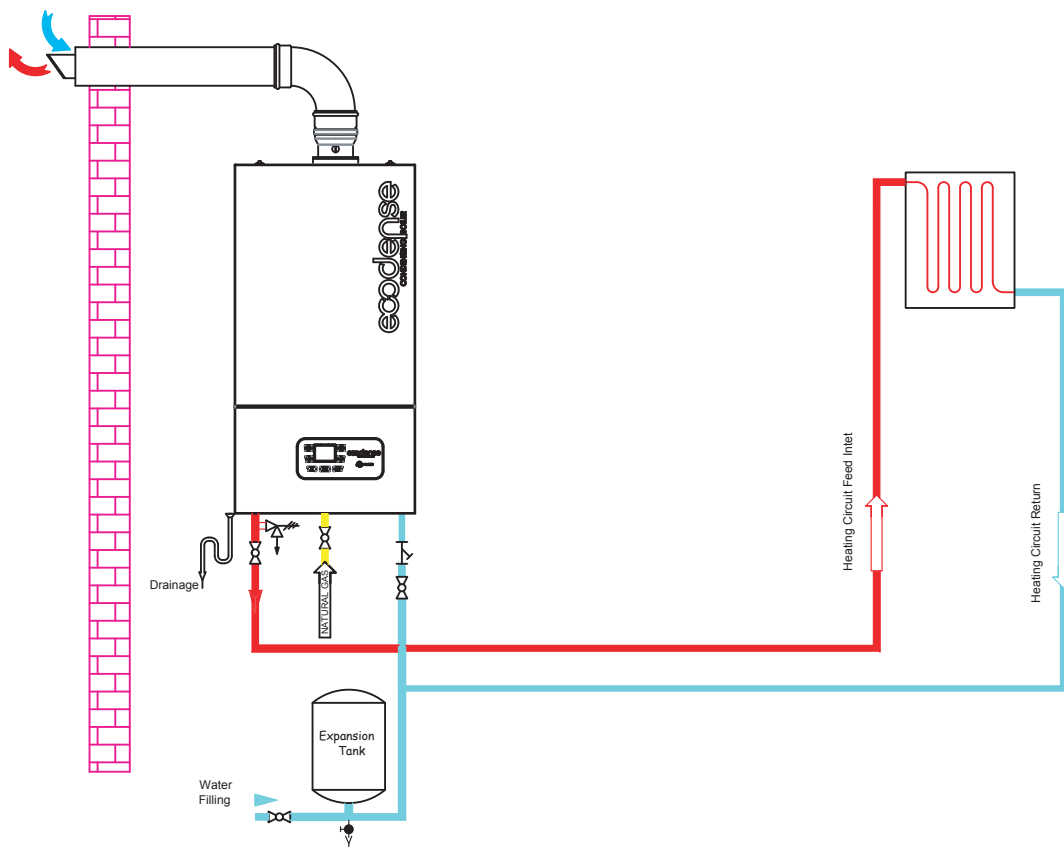



## ECODENSE CONDENSATING BOILER WT-S ONE 35-45 [BS] CIRCUIT DIAGRAM

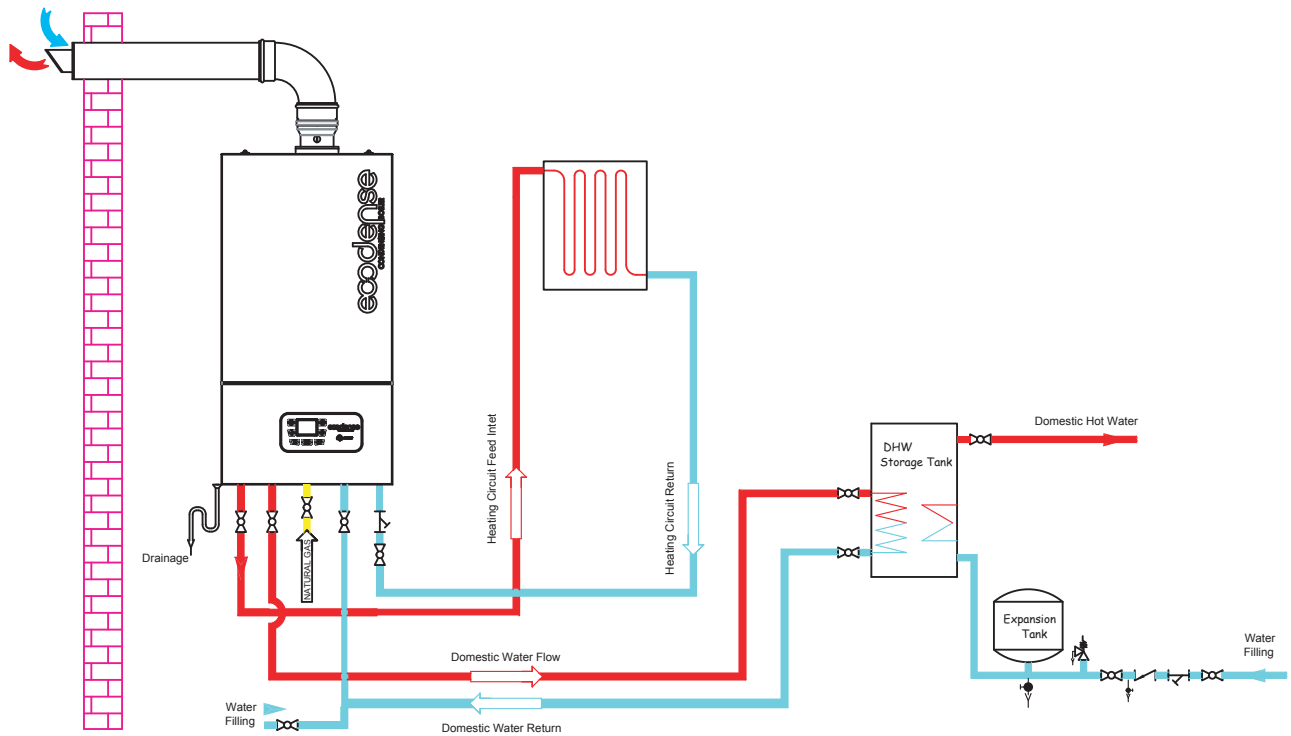

## ECODENSE CONDENSATING BOILER WT-S ONE 55-65 [BS] CIRCUIT DIAGRAM

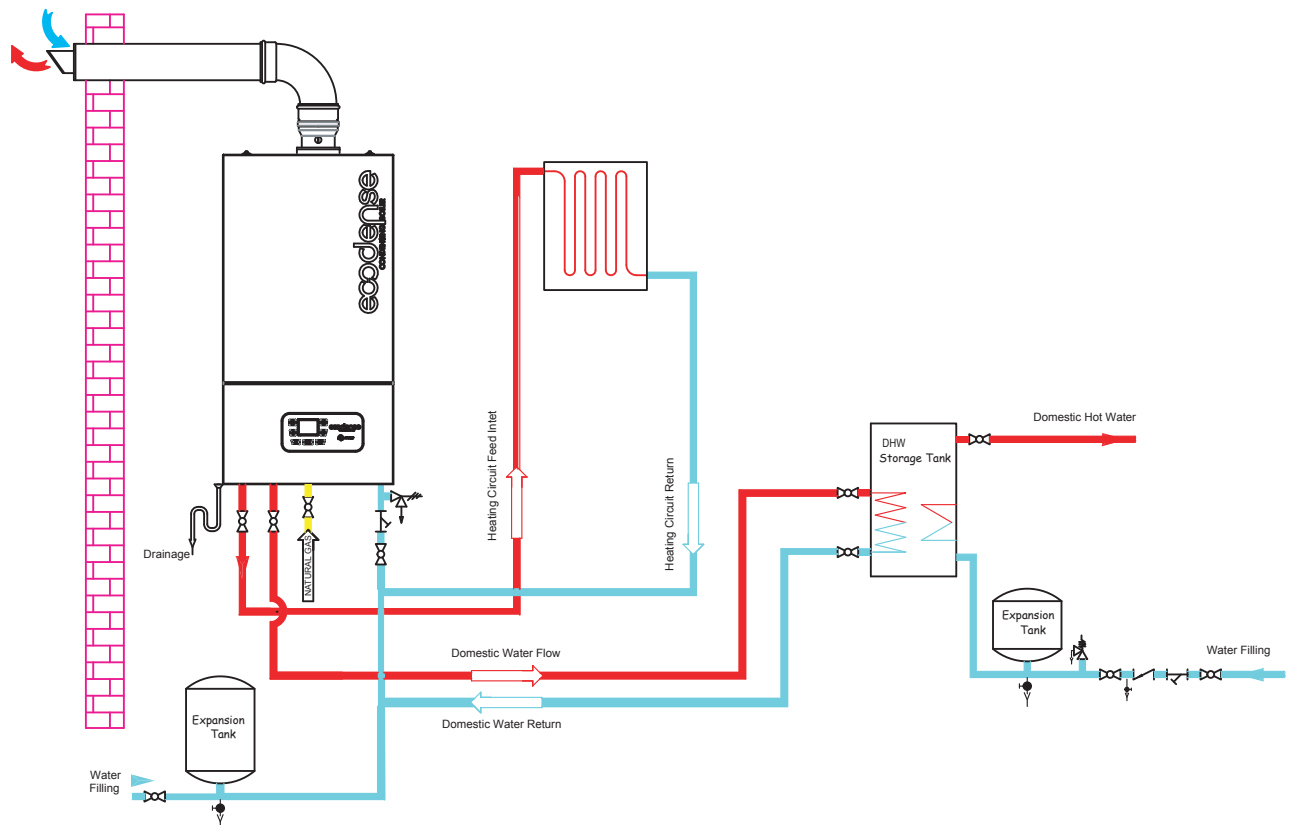

# ECODENSE CONDENSATING BOILER WT-S ONE 35-45 - [OH+EX] CIRCUIT DIAGRAM

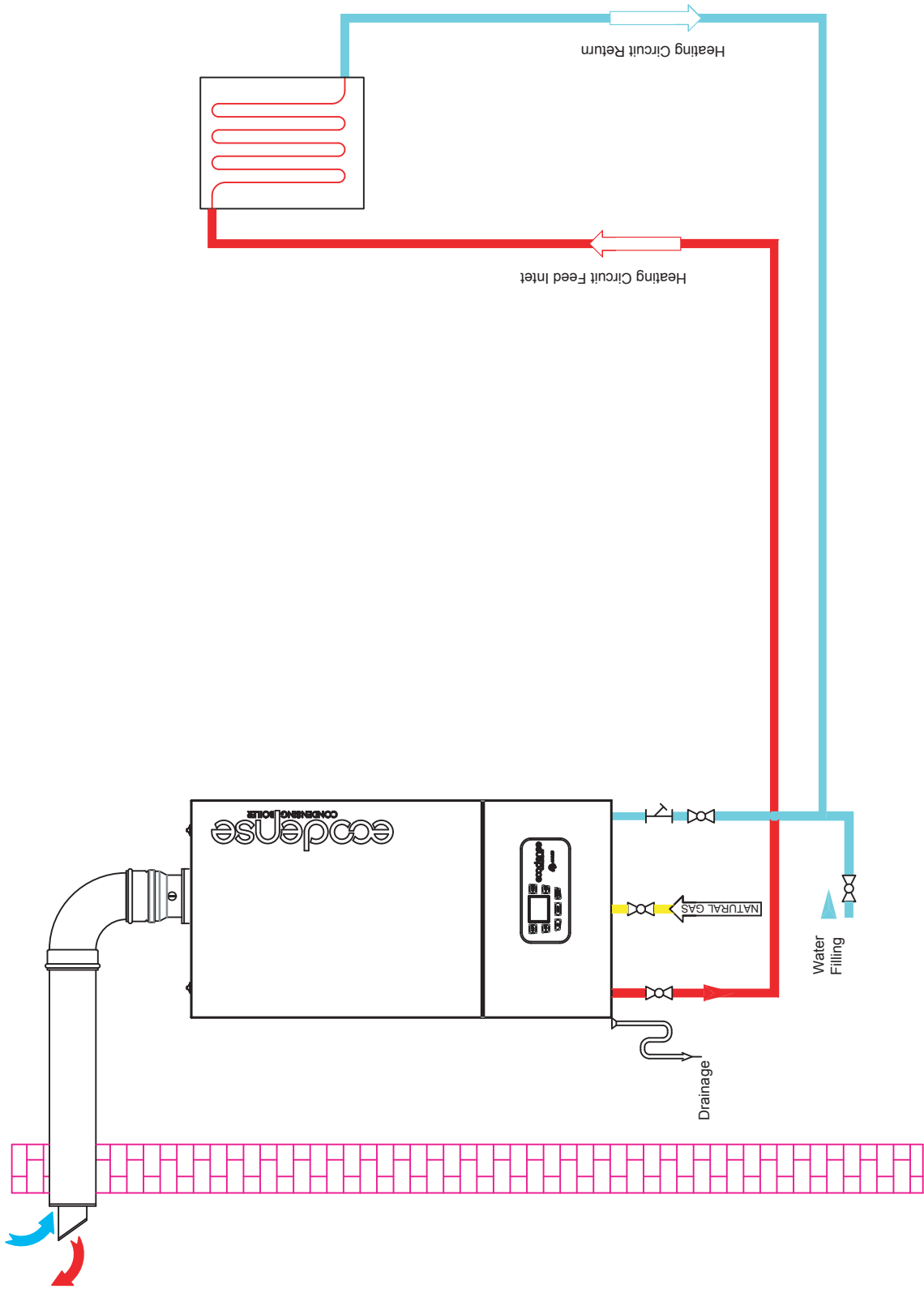

# ECODENSE WT-S DHW SERIES



CONDENSING BOILER WITH INTERNAL HOT WATER STORAGE TANK

## FEATURES

- ⊞ Heating and domestic water thermal capacity of 45, 55 ve 65 kW,
- ⊞ Prolonged high performance and high thermal efficiency with stainless steel Heat Exchanger with increased pipe diameters,
- ⊞ Optional hot water storage tank capacity options according to the domestic water need,
- ⊞ Comfort of instant, rapid use of hot water with high thermal efficiency boiler tank,
- ⊞ High modulation ratio 5:1,
- ⊞ Operation in low noise levels thanks to its body configuration with high heat and sound isolation,
- ⊞ Ability to operate with Natural Gas and LPG,
- ⊞ High efficiency circulation pump with automatic air purger, PWM driver,
- ⊞ Allows simple control with easy-to-use illuminated LCD panel; and viewing error codes and boiler information from this panel,
- ⊞ Superior safety features;
  - Flame safety control; ionization,
  - Flue gas temperature control,
  - Heating circuit overheating safety,
  - Frost protection,
  - Low water pressure safety,
- ⊞ Optional room thermostat connection,
- ⊞ Optional remote control,
- ⊞ Environmentally-friendly with lower NOx and CO emission rates.



107% Thermal efficient  
Stainless steel Heat  
Exchanger

Modulating primary circuit  
pump integrated to the  
boiler

Comfort of rapid and  
continuous hot water with  
high thermal efficiency hot  
water storage tank,

Internal Expansion Tank

## AREAS OF USE



House/Residence



Hotels



Hospitals



Schools



Plazas /  
Shopping Malls



Gyms



Swimming  
Pools

# ECODENSE **WT-S DHW** SERIES

## CONDENSING BOILER WITH INTERNAL HOT WATER STORAGE TANK

TECHNICAL SPECIFICATIONS	UNIT	WT-S DHW 45 L	WT-S DHW 45 H	WT-S DHW 45 XH	WT-S DHW 55 L	WT-S DHW 55 H	WT-S DHW 55 XH	WT-S DHW 65 L	WT-S DHW 65 H	WT-S DHW 65 XH
<b>Thermal Capacity</b>										
Maximum Heating Capacity	kW	45	45	45	55	55	55	65	65	65
Minimum Heating Capacity	kW	11	11	11	12	12	12	13,5	13,5	13,5
Maximum Heat Discharge for Heating (80°C / 60°C)	kW	42,4	42,4	42,4	53,4	53,4	53,4	64	64	64
Minimum Heat Output for Heating (80°C / 60°C)	kW	7,6	7,6	7,6	9,1	9,1	9,1	10,9	10,9	10,9
Maximum Heat Discharge for Heating (50°C / 30°C)	kW	45,8	45,8	45,8	57,2	57,2	57,2	68,2	68,2	68,2
Minimum Heat Load (50°C / 30°C)	kW	8,3	8,3	8,3	9,9	9,9	9,9	11,8	11,8	11,8
Maximum Domestic Water Capacity	kW	44,2	44,4	44,8	54,1	54,5	54,7	64,2	64,6	64,8
<b>Thermal Efficiency</b>										
Efficiency @ Pmax. (80°C / 60°C)	%	97,4%	97,3%	97,7%	97,5%	97,3%	97,7%	97,3%	97,2%	97,2%
Efficiency @ Pmin. (80°C / 60°C)	%	98,5%	98,6%	98,7%	98,8%	99,1%	98,2%	98,6%	98,3%	98,6%
Efficiency @ Pmax. (50°C / 30°C)	%	105,2%	105,3%	105,4%	105,3%	105,2%	105,1%	105,6%	105,3%	105,6%
Efficiency @ Pmin. (50°C / 30°C)	%	107,4%	107,6%	107,2%	107,2%	107,2%	107,2%	107,1%	107,3%	107,4%
Efficiency @ 30% (30°C)	%	108,7%	109,0%	108,2%	108,1%	108,7%	108,5%	108,6%	108,4%	108,7%
<b>Domestic Water Circuit</b>										
Domestic Water Temperature Adjustment Range	°C	10-65	10-65	10-65	10-65	10-65	10-65	10-65	10-65	10-65
Domestic Water Storage Tank Volume	L	60	90	120	60	90	120	60	90	120
Domestic Water Flow Rate in Continuous Use ( $\Delta T=25^{\circ}\text{C}$ , 20 °C / 45 °C)	L / dk	12,1	18,4	24,2	12,2	18,2	24,4	12,3	18,6	24,6
<b>Heating Circuit</b>										
Maximum Operating Temperature	°C	85	85	85	85	85	85	85	85	85
Maximum Operating Pressure	bar	4-6	4-6	4-6	4-6	4-6	4-6	4-6	4-6	4-6
Minimum Operating Pressure	bar	0,8	0,8	0,8	0,8	0,8	0,8	0,8	0,8	0,8
<b>Gas Properties</b>										
Gas Type	-	G20-G31	G20-G31	G20-G31	G20-G31	G20-G31	G20-G31	G20-G31	G20-G31	G20-G31
Gas Inlet Pressure (G20)	mbar	20	20	20	20	20	20	20	20	20
Gas Inlet Pressure (G31)	mbar	37	37	37	37	37	37	37	37	37
<b>Combustion Values</b>										
Maximum Flue Gas Outlet Temperature (50°C / 30°C)	°C	42	42	42	44	44	44	45	45	45
Maximum Flue Gas Outlet Temperature (80°C / 60°C)	°C	65	65	65	65	65	65	65	65	65
NOx Emission Class (EN 15502-1+A1)	-	5	5	5	5	5	5	5	5	5
<b>Electrical Values</b>										
Voltage & Frequency	V / Hz	230/50	230/50	230/50	230/50	230/50	230/50	230/50	230/50	230/50
Energy Consumption	W	190	190	190	210	210	210	300	300	300
<b>Hydraulic Circuit Properties</b>										
Gas Connection	inch	1/2"	1/2"	1/2"	1/2"	1/2"	1/2"	1/2"	1/2"	1/2"
Heating Circuit Inlet and Outlet Piping Diameter	inch	3/4"	3/4"	3/4"	3/4"	3/4"	3/4"	3/4"	3/4"	3/4"
Domestic Water Circuit Inlet and Outlet Piping Diameter	inch	1/2"	1/2"	1/2"	1/2"	1/2"	1/2"	1/2"	1/2"	1/2"
<b>General Features</b>										
Net (Dry) Weight	kg	95	110	125	100	115	130	105	120	135
Flue Diameter (Ø)	mm	80/125	80/125	80/125	80/125	80/125	80/125	80/125	80/125	80/125
G 20 Natural Gas, G 31 LPG										

# FLOW DIAGRAM

## CONNECTIONS

- A - Domestic Water Inlet
- B - Boiler Inlet
- C - Boiler Outlet
- D - Domestic Water Outlet
- E - Gas Inlet
- F - Condensate Outlet

## MAIN PARTS

- 1 - Stainless Steel Heat Exchanger
- 2 - Circulation Pump
- 3 - Fan
- 4 - Venturi / Mixer
- 5 - Gas Valve
- 6 - Silencer
- 7 - Hot Water Storage Tank
- 8 - Heating Water Expansion Tank
- 9 - Domestic Water Expansion Tank
- 10 - Domestic Water Temperature Sensor
- 11 - Inlet / Outlet Temperature Sensor
- 12 - 3-way Valve and Motor
- 13 - Pressure Sensor
- 14 - Flue Gas Sensor
- 15 - Cold Water Collector
- 16 - Hot Water Collector
- 17 - Water Filling Tap
- 18 - Safety Valve
- 19 - Ignition / Ionization Electrode
- 20 - Air Purger
- 21 - Condensate Trap

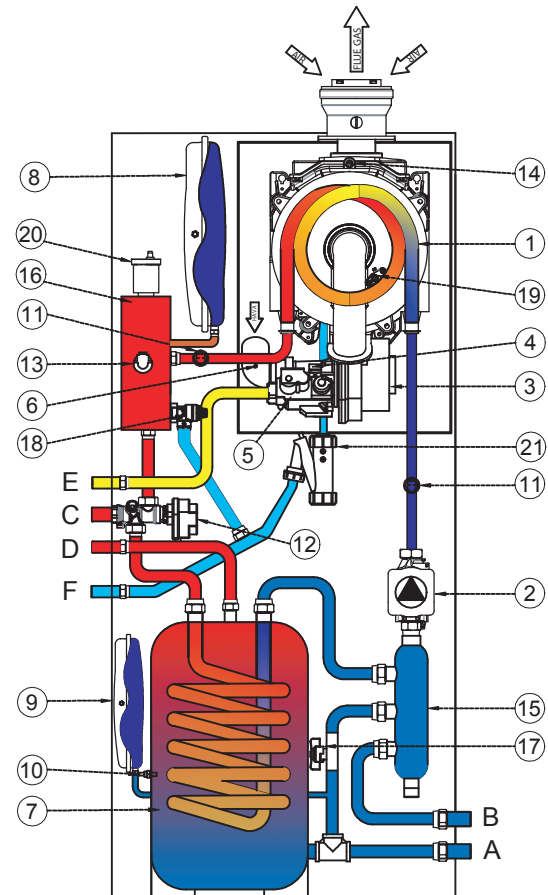

# OUTER DIMENSIONS & SIZES TABLE

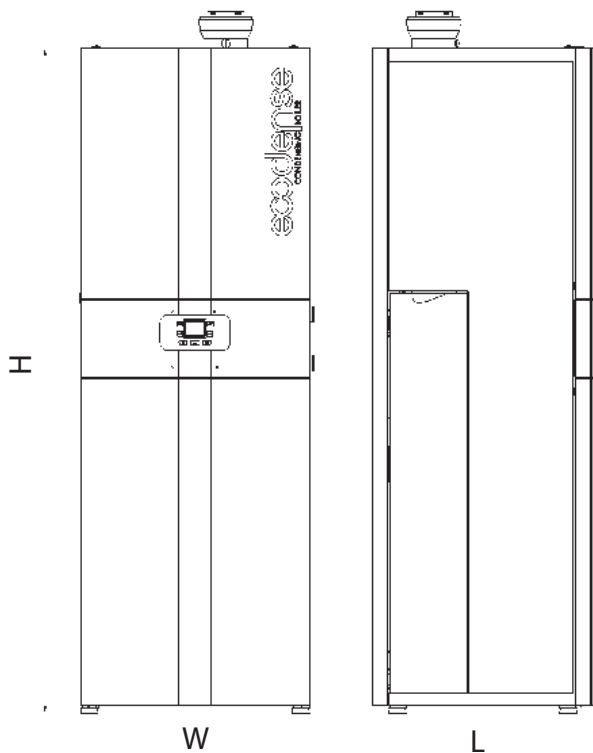

MODEL	W (mm)	H (mm)	L (mm)	Boiler Tank Volume (L)
WT-S DHW 45 L	575	1435	565	60
WT-S DHW 45 H	575	1665	565	90
WT-S DHW 45 XH	575	1935	565	120
WT-S DHW 55 L	575	1435	565	60
WT-S DHW 55 H	575	1665	565	90
WT-S DHW 55 XH	575	1935	565	120
WT-S DHW 65 L	575	1435	565	60
WT-S DHW 65 H	575	1665	565	90
WT-S DHW 65 XH	575	1935	565	120

CIRCUIT DIAGRAM OF ECODENSE CONDENSING BOILER WT-S+DHW WITH INTERNAL HOT WATER STORAGE TANK

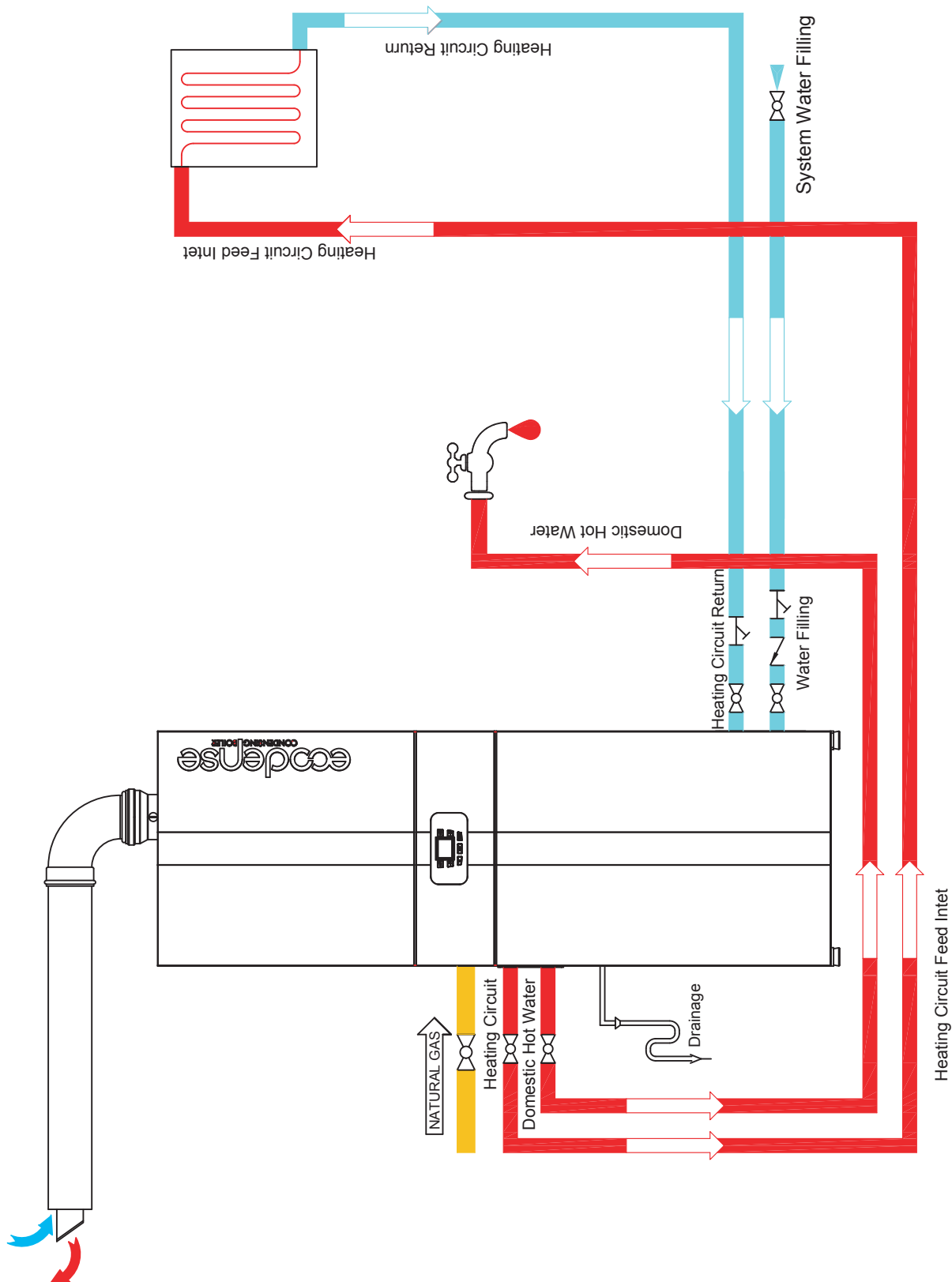

# FTC-X SERIES

## FLOOR TYPE CONDENSING BOILER



### FEATURES

- CO High thermal efficiency with Premix Condensing technology and micro-flame metal fiber coated steel burner,
- CO Aluminum silicate alloy cast casing Heat Exchanger that provides high operating efficiency with high heat transfer,
- CO A wide range of capacity (200, 270, 340, 410, 480, 550, 680 and 760 kW) in individual boilers and up to 12,160 kW in Cascade systems,
- CO High modulation ratio 5:1,
- CO Allows cascade connection up to total 16 boilers, including 1 master and 15 slave boilers,
- CO Easy control with illuminated, easy-to-use LCD panel,
- CO Allows programming with daily and weekly operation schedule,
- CO Allows seasonal heating program during summer and winter times,
- CO Ability to operate with Natural Gas and LPG,
- CO Provides space advantage in boiler room planning and conversions with its compact structure,
- CO Allows operation in lower sound volumes,
- CO Environmentally-friendly with lower NOx and CO emission rates.



107% Thermal efficient,  
Al-Si-Mg-alloy casting  
Heat Exchanger

Allows cascade up to  
16 boilers

High thermal efficiency  
with premix burner

### AREAS OF USE

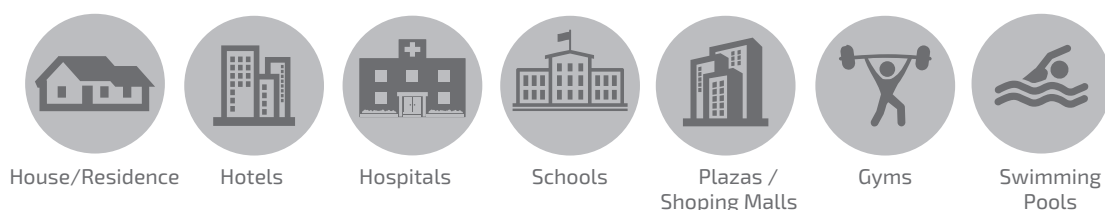

## ECODENSE **FTC-X** SERIES FLOOR TYPE CONDENSING BOILER

TECHNICAL SPECIFICATIONS	UNIT	FTC-X 200	FTC-X 270	FTC-X 340	FTC-X 410	FTC-X 480	FTC-X 550	FTC-X 680	FTC-X 760
<b>Thermal Capacity</b>									
Minimum Heating Capacity	kW	200	270	340	410	480	550	680	760
Maximum Heat Discharge for Heating (80°C / 60°C)	kW	30	35	45	55	65	75	90	105
Minimum Heat Output for Heating (80°C / 60°C)	kW	184	258	321	390	456	522	579	697,2
Maximum Heat Output for Heating (50°C / 30°C)	kW	28	36	44	53	60	72	80	96
Minimum Heat Output for Heating (50°C / 30°C)	kW	200	269	339	408	477	542	662	770,2
	kW	32	40	49	58	68	79	97	112
<b>Thermal Efficiency</b>									
Efficiency @ Pmaks. (80°C / 60°C)	%	98	98	98	98	98	98	98	98
Efficiency @ Pmin. (80°C / 60°C)	%	98,5	98,5	98,5	98,5	98,5	98,5	98,6	98,8
Efficiency @ Pmaks. (50°C / 30°C)	%	104	104	104	104,5	104,5	104,5	104,7	105
Efficiency @ Pmin. (50°C / 30°C)	%	107	107	107	107	107	107	107,1	107,8
Efficiency @ 30% (30°C)	%	107,4	107,5	107,4	107,3	107,2	107,7	107,9	108,2
<b>Domestic Water Circuit</b>									
Temperature Setting Range with External Hot Water Storage Tank	°C	10-65	10-65	10-65	10-65	10-65	10-65	10-65	10-65
<b>Heating Circuit</b>									
Maximum Heating Temperature	°C	85	85	85	85	85	85	85	85
Water Volume	L	18,67	22,96	26,42	32,64	36,9	41	48,6	53,3
Maximum Heating Water Pressure	bar	6	6	6	6	6	6	6	6
Minimum Heating Water Pressure	bar	0,8	0,8	0,8	0,8	0,8	0,8	0,8	0,8
<b>Gas Properties</b>									
Gas Type	-	G20-G31	G20-G31	G20-G31	G20-G31	G20-G31	G20-G31	G20-G31	G20-G31
Gas Inlet Pressure (G20)	mbar	20	20	20	20	20	20	20	20
Gas Inlet Pressure (G31)	mbar	37	37	37	37	37	37	37	37
<b>Combustion Properties</b>									
Flue Gas Temperature	°C	30-80	30-80	30-80	30-80	30-80	30-80	30-80	30-80
Flue Gas Mass Flow	kg/s	0,092	0,118	0,145	0,171	0,198	0,224	0,273	0,3027
NOx Class (EN 15502-1+A1)	-	6	6	6	6	6	6	6	6
<b>Installation Connection Properties</b>									
Condensing Connection Pipe Diameter	Ø	R3/4"	R3/4"	R3/4"	R3/4"	R3/4"	R3/4"	R3/4"	R3/4"
Gas Connection Pipe Diameter	Ø	R 1 1/4"	R 1 1/2"	R 1 1/2"	R 2"	R 2"	R 2"	R 2"	R 2"
Heating Circuit Inlet and Outlet Piping Diameter	Ø	R 2"	R 2"	DN65	DN65	DN65	DN65	DN65	DN65
<b>General Features</b>									
Net Weight	kg	260	270	296	320	350	360	372	490
Flue Diameter (Ø)	mm	160	160	160	200	200	200	200	200
G 20 Natural Gas, G 31 LPG									



## ECODENSE **FTC-X PLUS** SERIES FLOOR TYPE CONDENSING BOILER

TECHNICAL SPECIFICATIONS	UNIT	FTC-X 200 PLUS	FTC-X 270 PLUS	FTC-X 340 PLUS	FTC-X 410 PLUS	FTC-X 480 PLUS	FTC-X 550 PLUS
<b>Thermal Capacity</b>							
Maximum Heating Capacity	kW	230	300	380	450	480	600
Minimum Heating Capacity	kW	30	35	45	55	65	75
Maximum Heat Discharge for Heating (80°C / 60°C)	kW	214	285	356	429	498	570
Minimum Heat Output for Heating (80°C / 60°C)	kW	23	31	39	44	55	62
Maximum Heat Output for Heating (50°C / 30°C)	kW	230	305	380	455	530	605
Minimum Heat Output for Heating (50°C / 30°C)	kW	26	35	43	49	61	69
<b>Thermal Efficiency</b>							
Efficiency @ Pmaks. (80°C / 60°C)	%	98	98	98	98	98	98
Efficiency @ Pmin. (80°C / 60°C)	%	98,6	98,6	98,7	98,7	98,8	98,8
Efficiency @ Pmaks. (50°C / 30°C)	%	104,3	104,3	104,3	104,6	104,7	104,7
Efficiency @ Pmin. (50°C / 30°C)	%	107,1	107,1	107,2	107,2	107,3	107,3
Efficiency @ 30% (30°C)	%	107,4	107,5	107,5	107,5	107,4	107,6
<b>Domestic Water Circuit</b>							
Temperature adjustment range when external domestic water storage tank is used	°C	10-65	10-65	10-65	10-65	10-65	10-65
<b>Heating Circuit</b>							
Maximum Heating Temperature	°C	85	85	85	85	85	85
Water Volume	L	18,67	22,96	26,42	32,64	36,9	41
Maximum Heating Water Pressure	bar	6	6	6	6	6	6
Minimum Heating Water Pressure	bar	0,8	0,8	0,8	0,8	0,8	0,8
<b>Gas Properties</b>							
Gas Type	-	G20-G31	G20-G31	G20-G31	G20-G31	G20-G31	G20-G31
Gas Inlet Pressure (G20)	mbar	20	20	20	20	20	20
Gas Inlet Pressure (G31)	mbar	37	37	37	37	37	37
<b>Combustion Properties</b>							
Flue Gas Temperature	°C	30-80	30-80	30-80	30-80	30-80	30-80
Flue Gas Mass Flow	kg/s	0,092	0,118	0,145	0,171	0,198	0,224
NOx Class (EN 15502-1+A1)	-	6	6	6	6	6	6
<b>Installation Connection Properties</b>							
Condensing Connection Pipe Diameter	Ø	R3/4"	R3/4"	R3/4"	R3/4"	R3/4"	R3/4"
Gas Connection Pipe Diameter	Ø	R 1 1/4"	R 1 1/2"	R 1 1/2"	R 2"	R 2"	R 2"
Heating Circuit Inlet and Outlet Piping Diameter	Ø	R 2"	R 2"	DN65	DN65	DN65	DN65
<b>General Features</b>							
Net Weight	kg	260	270	296	320	350	360
Flue Diameter (Ø)	mm	160	160	160	200	200	200
G 20 Natural Gas, G 31 LPG							

## FLOW DIAGRAM

### CONNECTIONS

- A - Boiler Inlet
- B - Boiler Outlet
- C - Gas Inlet
- D - Air Inlet
- E - Condensate Outlet

### MAIN PARTS

- 1 - Al-Si-Mg Casting Heat Exchanger
- 2 - Premix Flame Tube
- 3 - Fan
- 4 - Venturi / Mixer
- 5 - Gas Valve
- 6 - Inlet / Outlet Temperature Sensor
- 7 - Pressure Sensor
- 8 - Flue Gas Sensor
- 9 - Limit Thermostat
- 10 - Ignition Transformer
- 11 - Ignition and Ionization Electrode
- 12 - Air Purger
- 13 - Condensate Trap

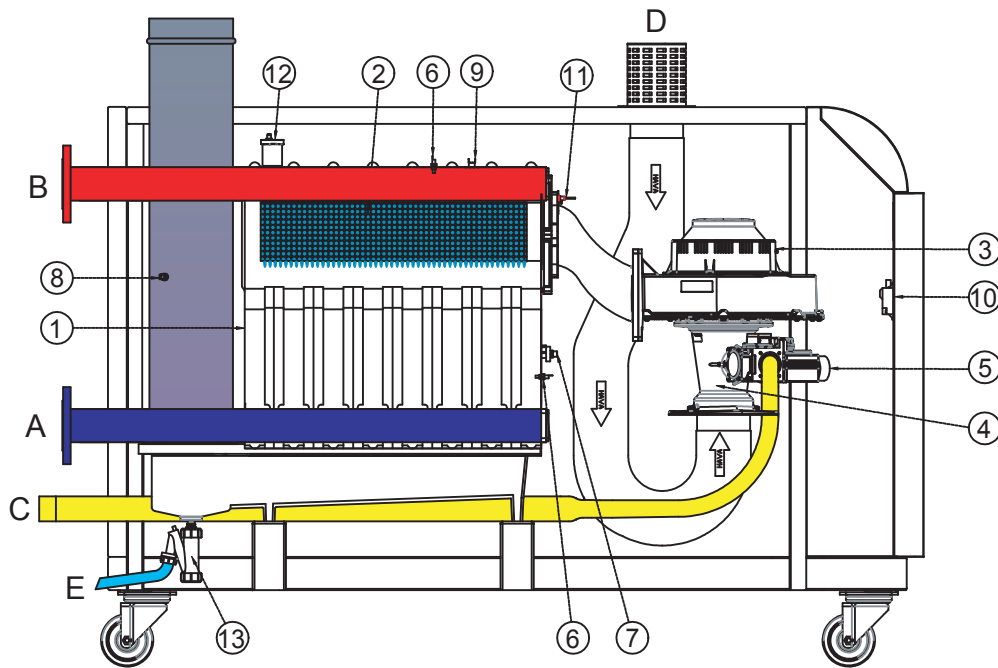

## OUTER DIMENSIONS & SIZES TABLE

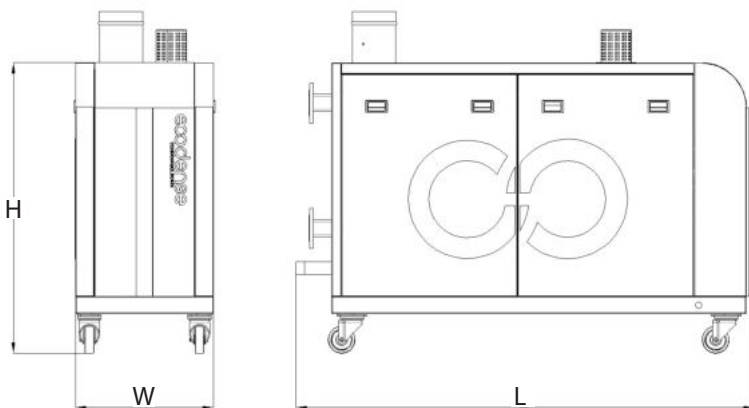

MODEL	W (mm)	H (mm)	L (mm)
FTC-X 200 NG	640	1345	1565
FTC-X 270 NG	640	1345	1565
FTC-X 340 NG	640	1345	1645
FTC-X 410 NG	640	1345	2120
FTC-X 480 NG	640	1345	2120
FTC-X 550 NG	640	1345	2120
FTC-X 680 NG	640	1345	2310
FTC-X 760 NG	640	1345	2405

# FTC-MG SERIES

## FLOOR TYPE CONDENSING BOILER



### FEATURES

- ☞ High thermal efficiency with Premix Condensing technology and micro-flame metal fiber coated steel burner,
- ☞ Al-Mg-Si alloy cast casing Heat Exchanger that provides high operating efficiency with high heat transfer,
- ☞ A wide range of capacity (800, 1000, 1200, 1400, 1800, 2200, 2500, 2600 and 3000 kW) in individual boilers and up to 48000 kW in Cascade systems,
- ☞ High modulation ratio 5:1,
- ☞ Allows cascade connection up to total 16 boilers, including 1 master and 15 slave boilers,
- ☞ Easy control with illuminated, easy-to-use LCD panel, Allows programming with daily and weekly operation schedule,
- ☞ Allows seasonal heating program during summer and winter times,
- ☞ Ability to operate with Natural Gas and LPG,
- ☞ Provides space advantage in boiler room planning and conversions with its compact structure,
- ☞ Allows operation in lower sound volumes,
- ☞ Environmentally-friendly with lower NOx and CO emission rates.



107% Thermal efficient,  
Al-Si-Mg-alloy casting  
Heat Exchanger

Allows cascade up to  
16 boilers

High thermal efficiency  
with premix burner

### AREAS OF USE

House/Residence	Hotels	Hospitals	Schools	Plazas / Shopping Malls	Gyms	Swimming Pools

## ECODENSE **FTC-MG** SERIES FLOOR TYPE CONDENSING BOILER

TECHNICAL SPECIFICATIONS	UNIT	FTC MG 5	FTC MG 6	FTC MG 7	FTC MG 8	FTC MG 10	FTC MG 12	FTC MG 13	FTC MG 14	FTC MG 16
<b>Thermal Capacity</b>										
Maximum Heating Capacity	kW	830	1040	1200	1400	1800	2200	2500	2600	3000
Minimum Heating Capacity	kW	95	120	155	200	270	250	275	300	355
Maximum Heat Discharge for Heating (80°C / 60°C)	kW	778	977	1171	1360	1758	2152	2349	2538	2922
Minimum Heat Output for Heating (80°C / 60°C)	kW	88	116	141	165	216	205	256	302	346
Maximum Heat Output for Heating (50°C / 30°C)	kW	832	1041	1246	1458	1869	2305	2512	2703	3118
Minimum Heat Output for Heating (50°C / 30°C)	kW	103	132	157	187	234	253	284	328	371
<b>Thermal Efficiency</b>										
Efficiency @ Pmaks. (80°C / 60°C)	%	98,1	98,2	98	98,1	98,2	98,1	98,3	98,2	98,3
Efficiency @ Pmin. (80°C / 60°C)	%	98,3	98,6	98,5	98,4	98,6	98,7	98,2	98,5	98,5
Efficiency @ Pmaks. (50°C / 30°C)	%	104,1	104,2	104,3	104,4	104,5	104,2	104,1	104,5	104,5
Efficiency @ Pmin. (50°C / 30°C)	%	107	107	107	107	107	107	107	107	107
Efficiency @ 30% (30°C)	%	107,4	107,5	107,4	107,3	107,3	107,3	107,3	107,2	107,7
<b>Domestic Water Circuit</b>										
Temperature Setting Range with External Hot Water Storage Tank	°C	10-65	10-65	10-65	10-65	10-65	10-65	10-66	10-65	10-65
<b>Heating Circuit</b>										
Maximum Heating Temperature	°C	85	85	85	85	85	85	85	85	85
Water Volume	L	54,2	65,9	77,6	89,3	112,7	136,1	159,5	182,9	206,3
Maximum Heating Water Pressure	bar	6	6	6	6	6	6	6	6	6
Minimum Heating Water Pressure	bar	0,8	0,8	0,8	0,8	0,8	0,8	0,8	0,8	0,8
<b>Gas Properties</b>										
Gas Type	-	G20-G31	G20-G31	G20-G31	G20-G31	G20-G31	G20-G31	G20-G31	G20-G31	G20-G31
Gas Inlet Pressure (G20)	mbar	20	20	20	20	20	20	20	20	20
Gas Inlet Pressure (G31)	mbar	37	37	37	37	37	37	37	37	37
<b>Combustion Properties</b>										
Flue Gas Temperature	°C	30-80	30-80	30-80	30-80	30-80	30-80	30-80	30-80	30-80
Flue Gas Mass Flow	kg/s	0,339	0,424	0,511	0,593	0,763	0,933	1,061	1,112	1,271
NOx Class (EN 15502-1+A1)	-	5	5	5	5	5	5	5	5	5
<b>Installation Connection Properties</b>										
Condensing Connection Pipe Diameter	Ø	1"	1"	1 1/4"	1 1/4"	1 1/4"	1 1/2"	1 1/2"	2"	2"
Gas Connection Pipe Diameter	Ø	1 1/2"	1 1/2"	2"	2"	2"	2 1/2"	2 1/2"	2 1/2"	3"
Heating Circuit Inlet and Outlet Piping Diameter	Ø	4"	4"	4"	5"	5"	5"	6"	6"	6"
<b>General Features</b>										
Net (Dry) Weight	kg	585	760	935	1120	1480	1830	2070	2185	2550
Flue Diameter (Ø)	mm	200	200	250	250	315	315	315	315	315
G 20 Natural Gas, G 31 LPG										

## FLOW DIAGRAM

### CONNECTIONS

- A - Boiler Inlet
- B - Boiler Outlet
- C - Gas Inlet
- D - Air Inlet
- E - Condensate Outlet

### MAIN PARTS

- 1 - Al-Si-Mg Casting Heat Exchanger
- 2 - Premix Flame Tube
- 3 - Fan
- 4 - Venturi / Mixer
- 5 - Gas Valve
- 6 - Inlet / Outlet Temperature Sensor
- 7 - Pressure Sensor
- 8 - Flue Gas Sensor
- 9 - Limit Thermostat
- 10- Ignition Transformer
- 11 - Ignition and Ionization Electrode
- 12- Air Purger
- 13- Condensate Trap

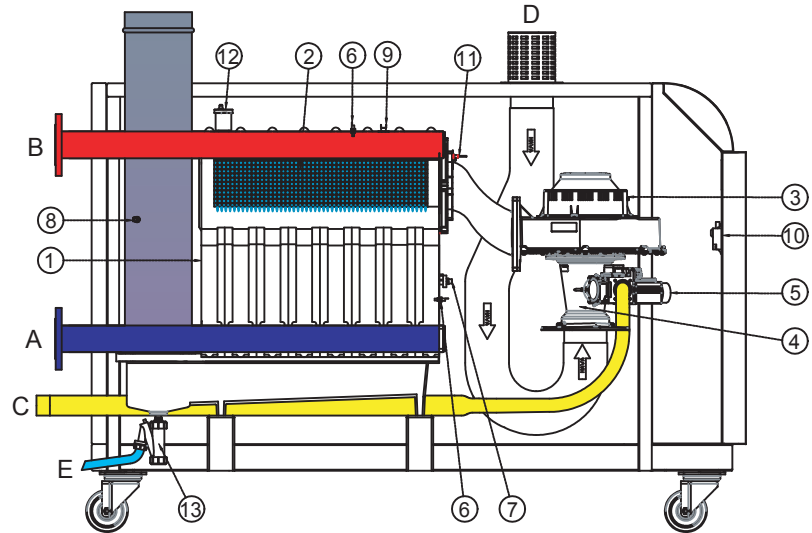

## OUTER DIMENSIONS & SIZES TABLE

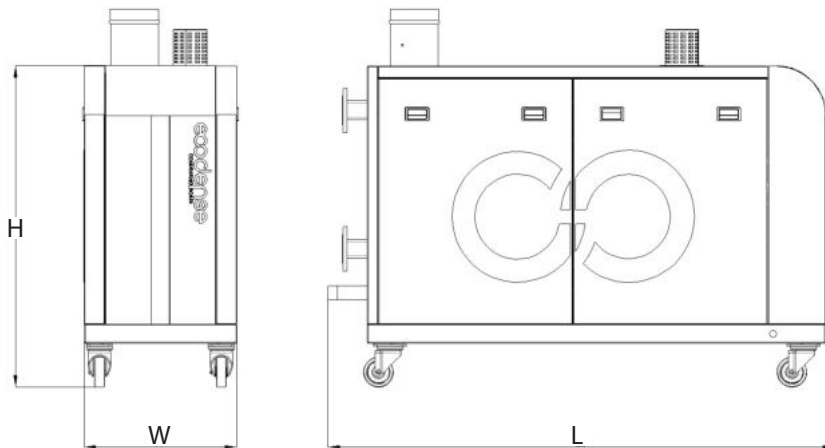

MODEL	W (mm)	H (mm)	L (mm)	Ağırlık (kg)
FTC - MG 5	930	2020	1875	585
FTC - MG 6	930	2020	1995	760
FTC - MG 7	930	2020	2120	935
FTC - MG 8	930	2020	2240	1120
FTC - MG 10	930	2020	2485	1480
FTC - MG 12	930	2020	2735	1830
FTC - MG 14	930	2020	2980	2185
FTC - MG 16	930	2020	3230	2550

# FT-S SERIES

## FLOOR TYPE CONDENSING BOILER

### FEATURES

- ⌘ Compact design for high thermal capacities in heating water and domestic water applications,
- ⌘ 5 different thermal capacity options: 315 kW, 400 kW, 530 kW, 800 kW and 1060 kW,
- ⌘ High thermal efficiency with stainless steel Heat Exchanger,
- ⌘ Rapid hot water demand in low water capacity,
- ⌘ Low thermal losses,
- ⌘ Energy saving through 5:1 modulating operation,
- ⌘ Daily and weekly operation scheduling,
- ⌘ Seasonal heat load program during summer and winter times,
- ⌘ Allows simple control with illuminated, easy-to-use LCD panel and viewing error codes and boiler information from a single panel,
- ⌘ Ability to operate with Natural Gas and LPG,
- ⌘ Allows operation in lower sound volumes,
- ⌘ Environmentally-friendly with low NOx and CO emissions,
- ⌘ Easy maintenance.



107% Thermal efficient  
Stainless steel Heat  
Exchanger

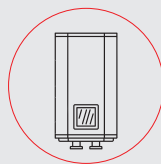

Allows cascade up to  
16 boilers



High thermal efficiency  
with premix burner

### AREAS OF USE



House/Residence



Hotels



Hospitals



Schools



Plazas /  
Shopping Malls



Gyms



Swimming  
Pools

## ECODENSE **FT-S** SERIES FLOOR TYPE CONDENSING BOILER

TECHNICAL SPECIFICATIONS	UNIT	FT-S 315	FT-S 530	FT-S 800	FT-S 1060
<b>Thermal Capacity</b>					
Maximum Heating Capacity	kW	315	530	800	1060
Minimum Heating Capacity	kW	65	110	180	215
Maximum Heat Discharge for Heating (80°C / 60°C)	kW	307,8	517,8	781,6	1035,6
Minimum Heat Output for Heating (80°C / 60°C)	kW	68,39	110,2	162,8	203,1
Maximum Heat Output for Heating (50°C / 30°C)	kW	337,7	568,2	860	1140
Minimum Heat Output for Heating (50°C / 30°C)	kW	67,5	116	183	219,1
<b>Useful Efficiency</b>					
Efficiency @ Pmaks. (80°C / 60°C)	%	97,7	97,7	97,7	97,8
Efficiency @ Pmin. (80°C / 60°C)	%	98,5	98,5	98	98,2
Efficiency @ Pmaks. (50°C / 30°C)	%	107,2	107,2	107,5	107,5
Efficiency @ Pmin. (50°C / 30°C)	%	107,4	107,6	107,2	107,1
Efficiency @ 30% (30°C)	%	108,7	109	108,2	108,6
<b>Domestic Water Circuit</b>					
Temperature Setting Range with External Hot Water Storage Tank	°C	10-65	10-65	10-65	10-65
<b>Heating Circuit</b>					
Maximum Operating Temperature	°C	85	85	85	85
Maximum Operating Pressure	bar	11	11	11	11
Minimum Operating Pressure	bar	1	1	1	1
<b>Gas Properties</b>					
Gas Type	-	G20	G20	G20	G20
Gas Inlet Pressure (G20)	mbar	20	20	20	20
<b>Combustion Values</b>					
Max. Flue Outlet Temperature (50°C / 30°C)	°C	45	45	45	45
Max. Flue Outlet Temperature (80°C / 60°C)	°C	70	70	70	70
NOx Emission Class (EN 15502-1+A1)	-	5	5	5	5
<b>Hydraulic Installation Properties</b>					
Gas Connection	inch	1/2"	1/2"	1/2"	1/2"
Heating Circuit Inlet and Outlet Piping Diameter	inch	2 1/2"	2 1/2"	4"	4"
<b>General Features</b>					
Net (Dry) Weight	kg	210	296	526	665
Flue Diameter (Ø)	mm	200	200	300	300
G 20 Natural Gas, G 31 LPG					

## FLOW DIAGRAM

### CONNECTIONS

- A - Boiler Inlet
- B - Boiler Outlet
- C - Gas Inlet
- D - Air Inlet
- E - Condensate Outlet

### MAIN PARTS

- 1 - Stainless Steel Heat Exchanger
- 2 - Premix Flame Tube
- 3 - Fan
- 4 - Venturi / Mixer
- 5 - Gas Valve
- 6 - Inlet / Outlet Temperature Sensor
- 7 - Pressure Sensor
- 8 - Flue Gas Sensor
- 9 - Limit Thermostat
- 10- Ignition Transformer
- 11 - Ignition and Ionization Electrode
- 12- Air Purger
- 13- Condensate Trap

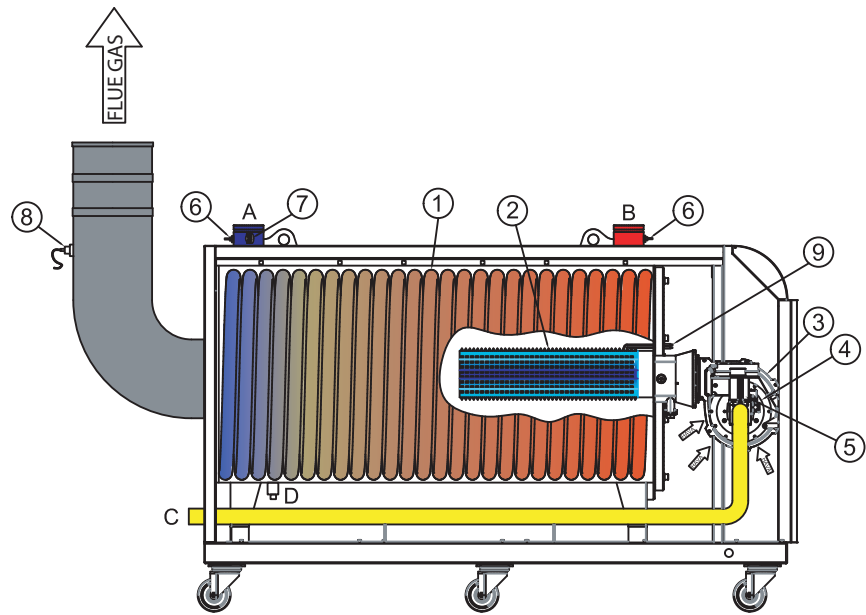

## OUTER DIMENSIONS & SIZES TABLE

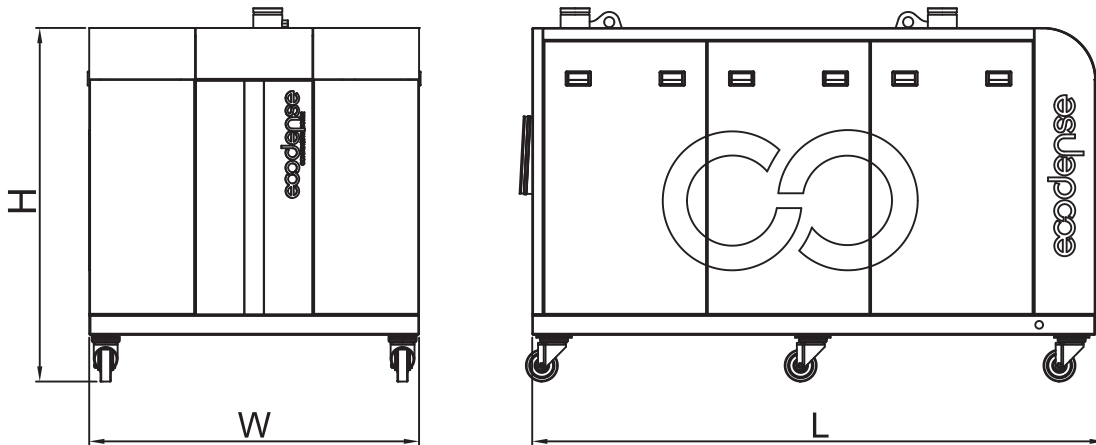

MODEL	W (mm)	H (mm)	L (mm)
FT-S 315	1000	1100	1250
FT-S 400	1000	1100	1400
FT-S 530	1000	1100	1750
FT-S 800	1300	1400	2000
FT-S 1060	1300	1400	2300



# ECODENSE CONDENSING BOILER FTC-X, FTC-MG, FT-S RADIATOR CIRCUIT DIAGRAM

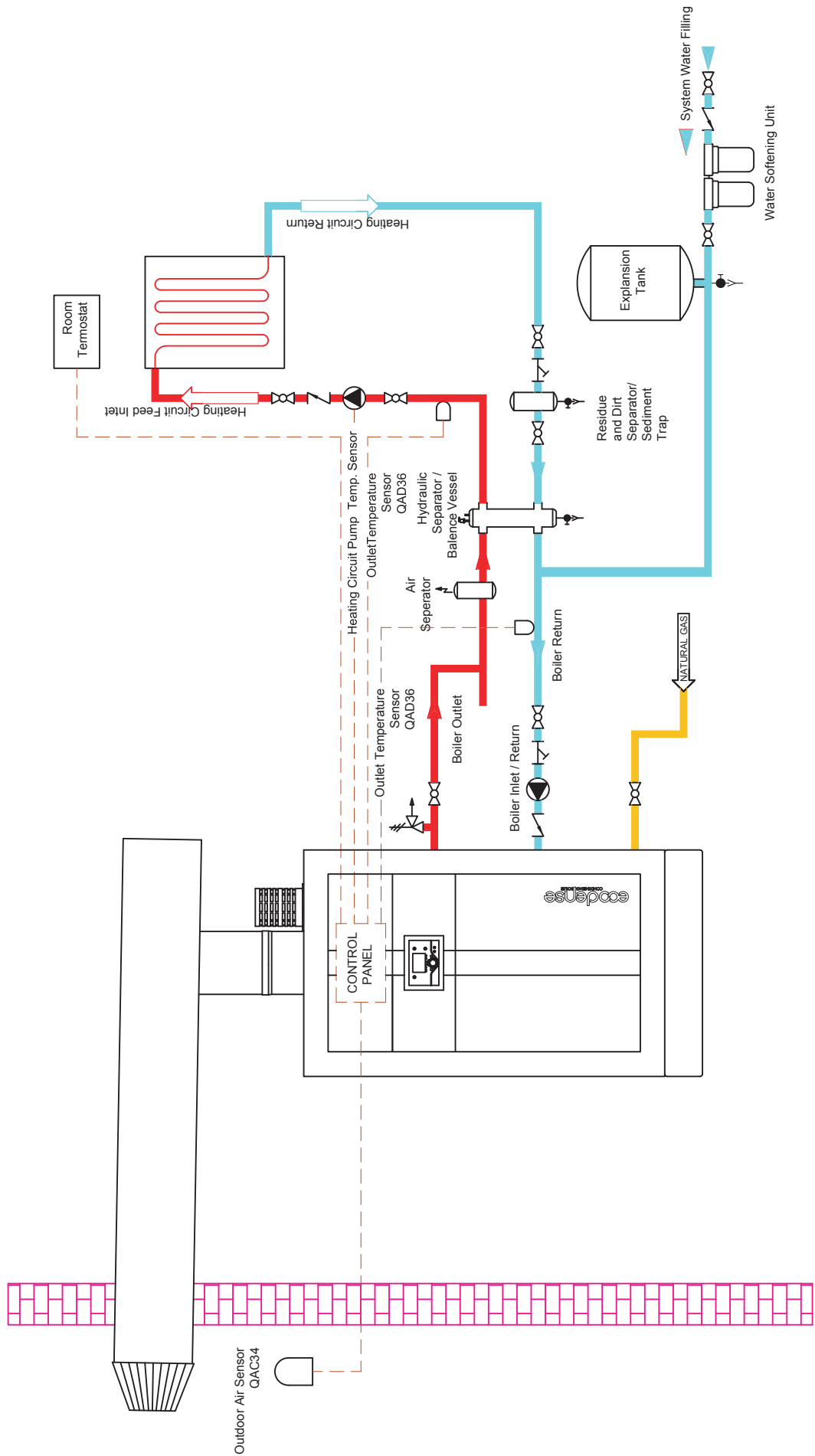

# ROOF TOP SERIES

## CONDENSING BOILER

### FEATURES

**ECODENSE** Roof Top series condensing boilers are designed as compact solutions for hot water production in many roof top applications such as shopping malls, office buildings, hospitals, hotels. Designed especially for outdoor applications, **ECODENSE** condensing boilers, when used as **CASCADE**, meet high-capacity energy requirements with line-up operation and also expand the life-cycle of boilers by ensuring equal aging in boilers.



- ∞ High efficiency with Condensing technology and Premix burner with micro-flame metal fiber coated steel flame tube,
- ∞ Energy saving through 5:1 modulating operation, 10 different capacity options between 65 kW-300 kW in ECODENSE RT One / Twin series,
- ∞ Ability to operate with Natural Gas and LPG,
- ∞ Easy hydraulic and gas circuit connections,
- ∞ Allows simple control with easy-to-use illuminated LCD panel; and viewing error codes and boiler information from one single panel,
- ∞ Allows programming of daily and weekly operation schedule,
- ∞ Allows seasonal heating program during summer and winter times,
- ∞ Operation in low noise values,
- ∞ Environmentally friendly with lower NOx and CO emission rates,
- ∞ Easy installation, operation and maintenance,



109% Thermal efficient, aluminum-alloy, spiral fine Heat Exchanger



Modulating primary circuit pump integrated to the boiler



Internal Back Current Damper



Internal balancing vessel, sediment trap and air separator



Internal gas filter and gas regulator



Internal gas detector



Packaged product ready for the system, equipped with installation safety equipment

### AREAS OF USE



House/Residence



Hotels



Hospitals



Schools



Plazas / Shopping Malls



Gyms



Swimming Pools

## ECODENSE **ROOF TOP** ROOFTOP SERIES WALL HUNG TYPE CONDENSING BOILER

TYPE	CAPACITY	NO OF BOILER	GAS INLET PRESSURE	MAXIMUM OPERATING PRESSURE
	kW		mbar	bar
ECODENSE RT-65 One	65	1	21	6
ECODENSE RT-80 One	80	1	21	6
ECODENSE RT-90 One	90	1	21	6
ECODENSE RT-100 One	100	1	21	6
ECODENSE RT-110 One	110	1	21	6
ECODENSE RT-115 One	115	1	21	6
ECODENSE RT-125 One	125	1	21	6
ECODENSE RT-150 One	150	1	21	6
ECODENSE RT-65 Twin	130	2	21	6
ECODENSE RT-80 Twin	160	2	21	6
ECODENSE RT-90 Twin	180	2	21	6
ECODENSE RT-100 Twin	200	2	21	6
ECODENSE RT-110 Twin	220	2	21	6
ECODENSE RT-115 Twin	230	2	21	6
ECODENSE RT-125 Twin	250	2	21	6
ECODENSE RT-150 Twin	300	2	21	6

### BOILER SAFETY

- ☞ When outdoor temperature goes below 4°C, the boiler automatically protects itself and prevents freezing.
- ☞ The boiler protects itself, when the temperature of flue gas exceeds the set value during operation;
- ☞ The boiler protects itself during unexpected high temperatures with combustion space safety thermostat.
- ☞ Gas detector for gas leaks inside the unit.

### STANDARD EQUIPMENT

- ☞ Circulation pump of primary hydraulic circuit circulating pump,
- ☞ Inlet and outlet collectors suitable for total boiler power,
- ☞ Check valve at feed line and safety valve at return line,
- ☞ Ball valve at feed and return lines of boilers,
- ☞ Balancing vessel with sludge, dirt and air separator suitable for total boiler power,
- ☞ Gas detector for gas leak control,
- ☞ Manometer and ball valve for gas line,
- ☞ Hydraulic circuit thermometer,
- ☞ Condensate trap for each boiler,
- ☞ Ventilation grills for air inlet and outlet,
- ☞ Eyebolt and carrying support for easy transport.

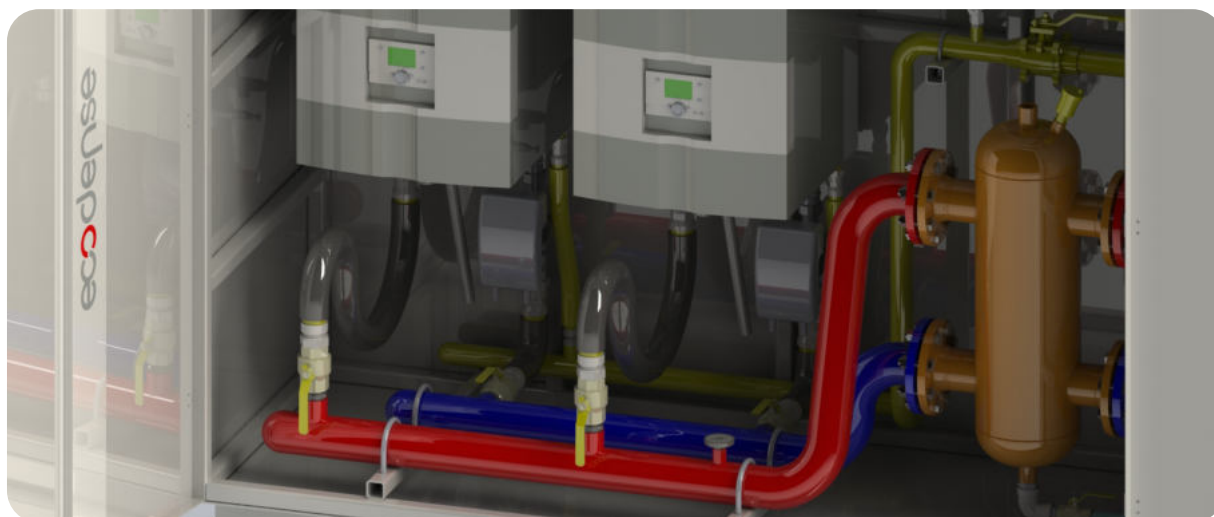
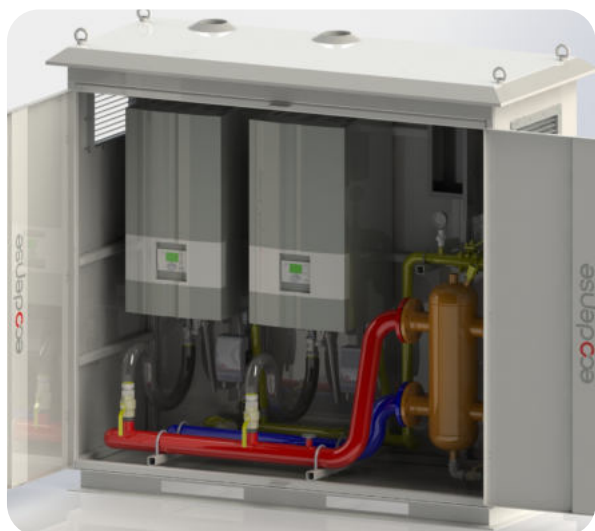

## OUTER DIMENSIONS & SIZES TABLE

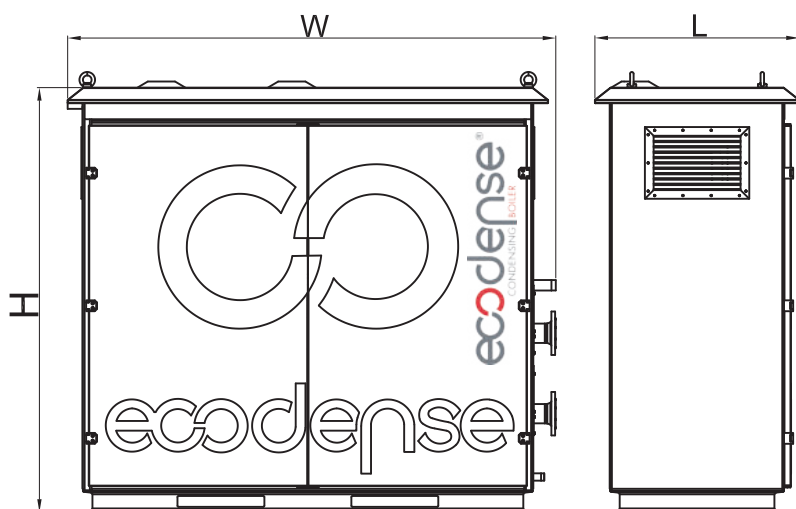

MODEL	W (mm)	H (mm)	L (mm)
ECODENSE RT-65 One	1960	1500	950
ECODENSE RT-80 One	1960	1500	950
ECODENSE RT-90 One	1960	1500	950
ECODENSE RT-100 One	1960	1500	950
ECODENSE RT-110 One	1960	1500	950
ECODENSE RT-115 One	1960	1500	950
ECODENSE RT-125 One	1960	1500	950
ECODENSE RT-150 One	1960	1500	950
ECODENSE RT-65 Twin	1960	2250	950
ECODENSE RT-80 Twin	1960	2250	950
ECODENSE RT-90 Twin	1960	2250	950
ECODENSE RT-100 Twin	1960	2250	950
ECODENSE RT-110 Twin	1960	2250	950
ECODENSE RT-115 Twin	1960	2250	950
ECODENSE RT-125 Twin	1960	2250	950
ECODENSE RT-150 Twin	1960	2250	950

# FLUE APPLICATIONS

Different solutions are offered for different applications: vertical or horizontal, separate or concentric flue sets. Flue sets in desired lengths may be used with the extension parts that can be added to flues. Please contact our sales team for detailed information.

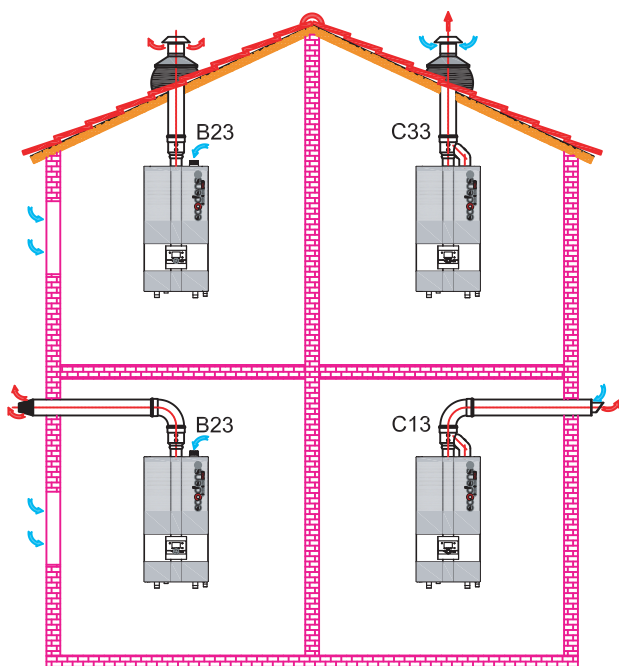

**B<sub>23</sub>** = Waste gas discharge is ensured by a flue extended outside from the place of the boiler. Combustion air is absorbed from the place of the boiler.



**C<sub>13</sub>** = Waste gas discharge and combustion air absorption is performed by concentric, horizontal flue.



**C<sub>33</sub>** = Waste gas discharge and combustion air absorption is performed by concentric, vertical flue.

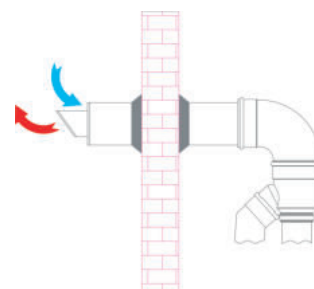
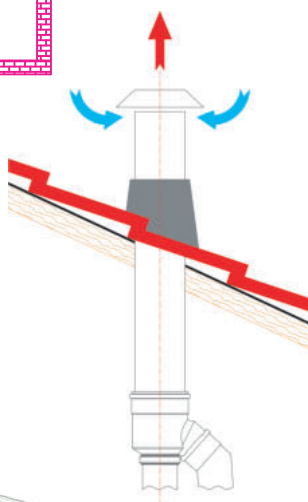
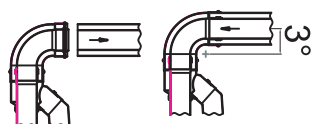

# FLUE ACCESSORIES



### Horizontal Type Hermetic Flue Set

Dimension	Application	Part Number
Ø 60 /100 mm, L= 500 mm, Ø 60 /100 mm, L=1000 mm, Ø 80 /125 mm, L=1000 mm, Ø 100 /150 mm, L=500 mm, Ø 100 /150 mm, L=1000 mm	Horizontal flue set may be used up to 10 m together with flue extension accessories.	<b>2 078 406 0103</b> (Ø 60 /100 mm, L= 500 mm) <b>2 078 406 0104</b> (Ø 60 /100 mm, L= 1000 mm) <b>2 078 406 0125</b> (Ø 80 /125 mm, L=1000 mm) <b>2 078 406 0151</b> (Ø 100 /150 mm, L=500 mm) <b>2 078 406 0152</b> (Ø 100 /150 mm, L=1000 mm)



### Vertical Type Hermetic Flue Set

Dimension	Application	Part Number
Ø 80 /125 mm	Vertical flue set may be used up to 11 m together with flue extension accessories.	<b>2 078 406 0126</b>

! For vertical flue set, a vertical flue adapter in the size of Ø80 /125! must be mounted to the boiler flue outlet



### Waste Gas Discharge Set

Dimension	Application	Part Number
Ø 80 mm PP Yatay Tip Ø 80 mm PP Dikey Tip	Flue accessories used for flue gas discharge in horizontal flue applications.	<b>2 078 406 0110</b> (Horizontal Type) <b>2 078 409 0500</b> (Vertical Type)



### Hermetic Flue Pipe

Dimension	Application	Part Number
Ø 80 /125 mm L= 500 mm, L= 1000 mm	May be used with horizontal flue set and vertical flue set.	<b>2 078 407 0050</b> (L=500 mm) <b>2 078 407 0100</b> (L=1000 mm)



### Flue Pipe

Dimension	Application	Part Number
Ø 80 mm	May be used with horizontal flue set and vertical flue set.	<b>2 078 401 00 80</b>



### Flue Connection Pipe

Dimension	Application	Part Number
PP Boru Ø 80 x 500 mm M-F PP Boru Ø 80 x 1000 mm M-F PP Boru Ø 100 x 1000 mm M-F	May be used with horizontal flue set and vertical flue set.	<b>2 078 409 0500</b> (Ø 80 x 500 mm M-F) <b>2 078 409 1000</b> (Ø 80 x 1000 mm M-F) <b>2 078 409 1100</b> (Ø 100 x 1000 mm M-F)



### Hermetic Elbow

Dimension	Application	Part Number
90 ° Ø 80 /125 mm	May be used in horizontal and/or vertical flue applications.	<b>2 078 407 0500</b>

! Use of each 90 ° elbow requires 1000 mm decrease in vertical/horizontal distance



Hermetic Elbow		
Dimension	Application	Part Number
45° Ø 80 / 125 mm	May be used in horizontal and/or vertical flue applications. <small>*Use of each 45° elbow requires 500 mm decrease in vertical/horizontal distance</small>	<b>2 078 407 0450</b>



Separate Adaptor		
Dimension	Application	Part Number
Ø 80 / 125 mm	The apparatus that must be used in boiler flue outlet and external air inlet when vertical and/or horizontal flue set is used.	<b>2 078 404 0130</b>



Flanged Adaptor		
Dimension	Application	Part Number
Ø 60 / 80 mm	Auxiliary equipment used in horizontal and/or vertical type hermetic flue accessories.	<b>2 078 404 0160</b>



Flue Klappe		
Dimension	Application	Part Number
Ø 80, 100 / 100 mm	Angled klappe accessory that must be mounted to each boiler's flue outlet in cascade system. 2 types of boiler connection is available: Ø 80 and Ø 100 mm as boiler flue connection and Ø 100 mm collector connection	<b>2 078 404 0390</b> (Ø 80 mm) <b>2 078 404 0392</b> (Ø 100 mm)



Additional Flue Set		
Dimension	Application	Part Number
(Ø 160 mm)	Additional flue connection accessory used in cascade system.	<b>2 078 403 1160</b>



Additional Flue Set		
Dimension	Application	Part Number
(Ø 200 mm)	Additional flue connection accessory used in cascade system.	<b>2 078 403 1200</b>



Condensate Trap		
Dimension	Application	Part Number
(Ø 1/2")	The accessory used for discharging the water occurred as a result of the Condensing of boiler's smoke gases.	<b>2 078 404 0 135</b> (Ø 1/2")

# NEW GENERATION BUILDING MANAGEMENT SYSTEM INTEGRATIONS FOR WALL AND FLOOR TYPE CONDENSING BOILERS

## ECOBIX

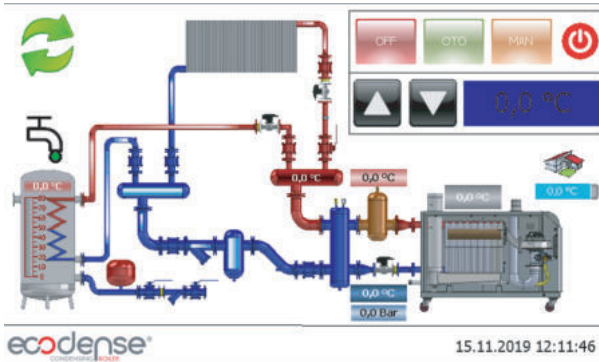

We have developed our ECOBOX product to integrate our condensing boilers in the digitalized world. You are now able to control via ECOBOX panel the entire process of your floor-type or wall-type boilers from any point within your existing ethernet network. In addition, it is now easier to switch to many new generation communication protocols used by the industrial automation world.

You can manage more than one condensing boilers, operating either as cascade or independently, by connecting them to ECOBOX system by ethernet system only.

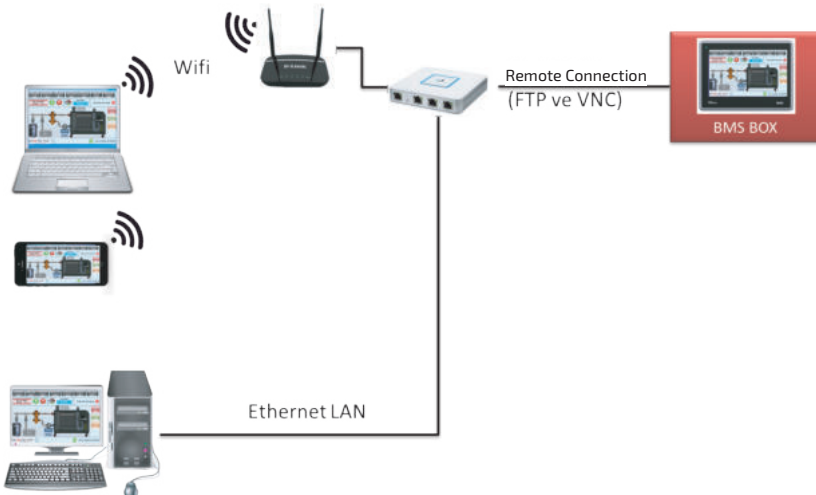
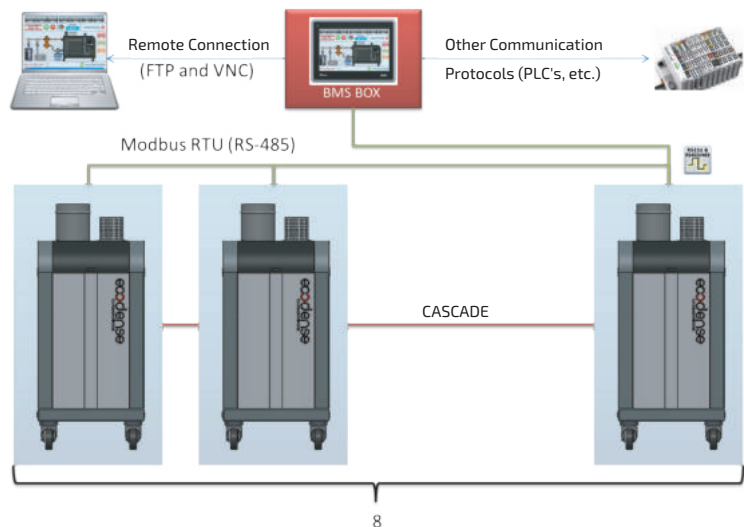
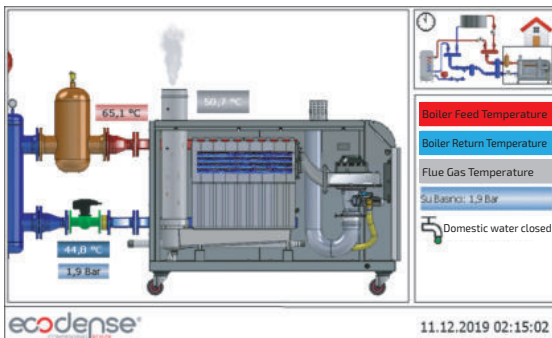

You can access all data through mobile phones, tablets or computers. No need for technical information to create a connection. You can access the system in 3 steps by any remote connection program by writing your IP address and username only. You can also provide the remote connection program from our sales representatives free of charge.



## ALMOST LIMITLESS DATA RECORDING

Ecobox continuously monitors your boilers and keeps their records. This way, it ensures much easier failure analyses and maintenance, operation processes. You can examine all related data and understood your condensing boilers' status easily.

- ☞ Flue gas temperature,
- ☞ Water pressure,
- ☞ Outdoor temperature,
- ☞ Flow and return temperatures,
- ☞ Cascade Return Temperature,
- ☞ Cascade Return Temperature,
- ☞ Boiler Set Temperature,
- ☞ Ionization density,
- ☞ Pump Status,
- ☞ Operating mode,

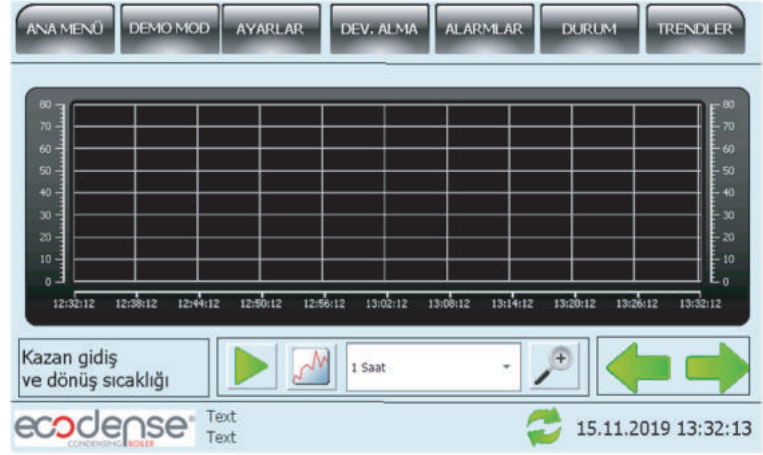

It keeps much more data in its memory and enables you access such data any time you want and even download in excel format.

Durum	Aktif Olma Zamanı	Açıklama	Görülme Zamanı
Normal	25.09.2020 21:46:20	Fan hız eşiğine ulaşılmadı.	25.09.2019 05:30:
Normal	25.09.2020 11:37:42	Fan hız eşiğine ulaşılmadı.	25.09.2019 05:30:
Active	29.09.2019 10:47:02	Fan hız eşiğine ulaşılmadı.	
Inactive	29.09.2019 09:37:38	Fan hız eşiğine ulaşılmadı.	
Inactive	29.09.2019 09:36:35	Fan hız eşiğine ulaşılmadı.	
Inactive	29.09.2019 09:02:44	Fan hız eşiğine ulaşılmadı.	
Inactive	27.09.2019 03:50:52	Fan hız eşiğine ulaşılmadı.	
Normal	27.09.2019 03:49:16	Boylar sıcaklık sensörü 1 hatası	27.09.2019 03:49:
Normal	25.09.2019 23:19:23	Fan hız eşiğine ulaşılmadı.	27.09.2019 03:48:
Normal	25.09.2019 23:18:31	Dış hava sensörü hatası	27.09.2019 03:48:
Normal	25.09.2019 21:52:45	Fan hız eşiğine ulaşılmadı.	27.09.2019 03:48:
Normal	25.09.2019 21:50:32	Fan hız eşiğine ulaşılmadı.	27.09.2019 03:48:
Normal	25.09.2019 21:44:04	Fan hız eşiğine ulaşılmadı.	27.09.2019 03:48:
Normal	25.09.2019 21:07:50	Dış hava sensörü hatası	27.09.2019 03:48:
Normal	25.09.2019 07:00:31	Fan hız eşiğine ulaşılmadı.	27.09.2019 03:48:
Normal	25.09.2019 06:38:12	Dış hava sensörü hatası	27.09.2019 03:48:
Normal	25.09.2019 06:24:59	Fan hız eşiğine ulaşılmadı.	27.09.2019 03:48:
Normal	25.09.2019 05:29:58	Dış hava sensörü hatası	25.09.2019 05:30:
Normal	25.09.2019 05:20:26	Boylar sıcaklık sensörü 1 hatası	25.09.2019 05:20:

Active: 1 Inactive: 4 Ack: 0 Normal: 16 Disabled: 0 [21 / 21]

Alarm records menu enables you to access all fault histories of condensing boilers on a daily or hourly basis.

# MAGNETIC SEDIMENT TRAP

The substances like dirt, sludge, sediment, sand, etc., present in the installation water may result in failure of boiler and installation components, stress on heat transfer surfaces and decrease in efficiency. In order to prevent this, a sediment trap to be added to the system prevents penetration of such substances into the installation and ensures efficient operation of the system. You can choose the magnetic sediment trap suitable for your boiler capacity (kW) and system capacity (kcal/h) of the boiler you have been using or just purchased.



## CAPACITY TABLE

System Capacity (kw)	System Capacity (kcal/h)	dT(°C)	Flow Rate (m3/h)	Compatible product str.	Max.flow rate for product dia. for mag. sed. trap (m3/h)	Magnetic Sediment Trap Product Code	Insulation
35	30100	20	1,51	1	2,11	546306	Optional
45	38700	20	1,94	1	2,11	546306	Optional
55	47300	20	2,37	1 1/4	3,47	546307	Optional
65	55900	20	2,80	1 1/4	3,47	546307	Optional
90	77400	20	3,87	1 1/2	5,42	546308	Optional
115	98900	20	4,95	1 1/2	5,42	546308	Optional
130	111800	20	5,59	2"/DN50 (flanged)	8,20/8,47	546309/546650	Optional/Insulated
170	146200	20	7,31	2"/DN50 (flanged)	8,20/8,47	546309/546650	Optional/Insulated
230	197800	20	9,89	DN65	14,32	546660	Insulated
345	296700	20	14,84	DN80	21,69	546680	Insulated
460	395600	20	19,78	DN80	21,69	546680	Insulated
575	494500	20	24,73	DN100	33,89	546610	Insulated
690	593400	20	29,67	DN100	33,89	546610	Insulated
805	692300	20	34,62	DN125	58,80	546612	Insulated
920	791200	20	39,56	DN125	58,80	546612	Insulated
1035	890100	20	44,51	DN125	58,80	546612	Insulated
1150	989000	20	49,45	DN125	58,80	546612	Insulated
1265	1087900	20	54,40	DN125	58,80	546612	Insulated
1380	1186800	20	59,34	DN150	86,20	546615	Insulated
1495	1285700	20	64,29	DN150	86,20	546615	Insulated
1610	1384600	20	69,23	DN150	86,20	546615	Insulated
1725	1483500	20	74,18	DN150	86,20	546615	Insulated
300	258000	20	12,90	DN65	14,32	546660	Insulated
375	322500	20	16,13	DN80	21,69	546680	Insulated
3000	2580000	20	129,00	DN200	146,00	546620	Insulated

# OPTIONAL ACCESSORIES



## CIRCULATION PUMP

With high efficiency circulation pump, you save energy  
According to capacity and product type/series, boiler circulation pump may vary



## QAZ36 CABLE TEMPERATURE SENSOR

Operable at the range of 0°C to 95°C. +0.5/-0.5 Kelvin tolerance. 2 meters long. Used for hot water storage tank. 1 pcs is required for hot water tank in CASCADE systems.



## CHECK VALVE

The check valves with suitable connection diameter must be mounted on the installation according to the circuit diagram.



## OC1345.06 CASCADE MODULE

For wall mounted boilers, 16 boilers, including 1 master and 15 slave boilers, can be controlled as cascade.

For 2 or more boilers, the CASCADE module must be used depending on the number of boilers.



## 6-BAR SAFETY VALVE

A spring safety valve must be mounted on the installation according to the circuit diagram, without any limitation of valve or otherwise.



## AVS-74 CONTROL PANEL

Controls the parameters contained in the boiler control card. Connected to the boiler control card via the connection cable. Different language options that are not in the standard Control Panel are active. (DE, EN, FR, IT, NL, ES, DA, SV, FI, PT, PL, CS, SK, SL, HU, EL, TR, RU, SR)



## QAC34 OUTDOOR AIR SENSOR

Operable at the range of -50°C to 70°C. Allows connection at maximum 120 meters using cable with 1.5 mm<sup>2</sup> section. +1/-1 Kelvin tolerance. 1 pcs must be used in cascade or single systems. Adjust the system temperature according to the outdoor temperature. When the outdoor temperature drops below 4°C, the "Frost Protection" mode is activated.



## AVS75

Used for 3-way valve. Maximum 3 can be connected to 1 CASCADE system.



## OAD36 STRAP-ON TEMPERATURE SENSOR

Operable at the range of -30°C to 125°C. Allows connection at maximum 80 meters using cable with 1 mm<sup>2</sup> section. 0.5/-0.5 Kelvin tolerance. 1 pcs must be required for single boilers, 2 for CASCADE system: 1 at hot water inlet, 1 at cold water inlet.



## QAA5 CASCADE ROOM UNIT

Different room comfort setting values and operating modes can be selected. Ensures transfer of CASCADE system depending on the room temperature.

# CLOSED SYSTEM CIRCUIT COMPONENTS

## MANOMETER

Minimum one manometer covering a range of 0-6 bars must be installed to the system. The manometer must be placed in a manner easily visible from the charging point, and preferably, must be connected to the same point with the expansion tank.

## EXPANSION TANK

Used to prevent any damage to the pipes and mechanic parts of the system due to high pressure caused by excess water occurred as a result of increased volume of hot water.

## AIR SEPARATOR

The air inside the installation dissolves by increase of temperature and circulates through the system in gas form. This results in cavitation in the installation, decrease in efficiency and noise. The air inside the installation can be removed by use of an air separator.

## BALANCE VESSEL

The main duty of balance vessel is to provide thermal equilibrium through enabling mixing of cold fluid from the installation with hot water from the boiler. Additionally, they are used to compensate potential pressure differences in a system containing multiple pumps. The balance vessel must be positioned upright.

## SIZING OF BALANCING VESSEL

☞ In order for healthy operation of balance vessel, it must be designed in proper dimensions.

☞ The discharged water temperature of the boiler should be measured at top of the balance vessel. For this, a 1/2" sleeve must be welded on top of the vessel; also an air purger must be mounted.

☞ Dimensions shown below are minimum dimensions required to be applied.

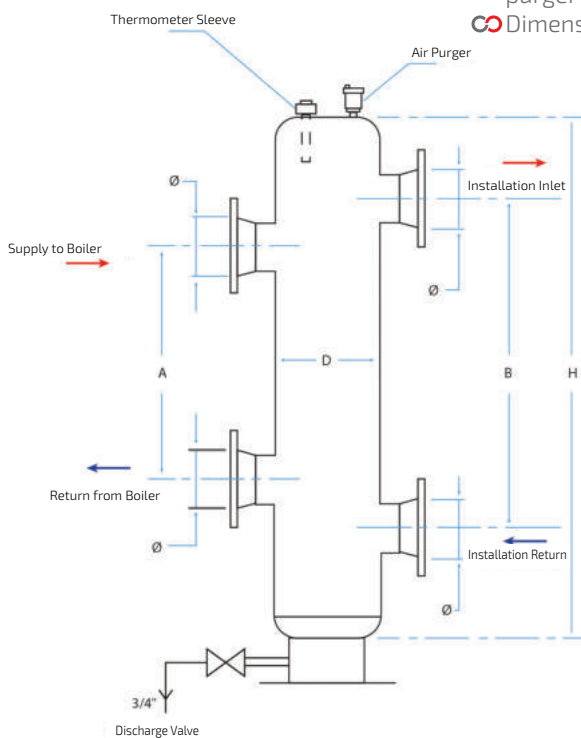

System Capacity	A	B	H	Balancing Vessel Diameter (D)	Inlet/Outlet Diameter (Q)
kW	cm	cm	cm	mm	mm
65	33	38	48	100	50
90	38	44	55	125	50
115	42	47	59	125	65
130	47	54	68	150	65
170	54	62	77	150	80
230	59	67	84	200	80
345	72	82	103	200	100
460	83	95	119	250	100
575	93	106	133	250	125
690	102	116	145	300	125
805	110	126	157	300	150
920	118	134	168	350	150
1035	131	150	188	350	150
1150	138	157	197	400	200
1265	144	164	206	400	200
1380	150	171	214	450	200
1495	155	178	222	450	200
1610	162	185	230	450	200
1725	169	192	238	450	200

Total Capacity (kW)	Expansion Tank Capacity (L)	Total Capacity (kW)	Expansion Tank Capacity (L)
65	60	270-360	300
90	80	460-570	500
114	100	685-800	750
130	125	920	900
180	150	1030	1000
228	200	1140	1250

ecodense<sup>®</sup>  
CONDENSING BOILER

**HEAD OFFICE**

Address : Esentepe Mah. Milangaz Cad. No: 75 Kat: 3 Monumento Plaza Kartal / İstanbul / TÜRKİYE

Tel. : +90 216 442 93 00 (pbx) Fax. : +90 216 370 45 03

Mail : info@ecodenseboilers.com Web : www.ecodenseboilers.com

**BRANCH OFFICE:**

Bonici, Autobuska Stanica Br. 17-18 Tivat-Montenegro

**FACTORY**

Address : Türkgücü OSB Bülent Ecevit Bulvarı No: 11 Çorlu / Tekirdağ / TÜRKİYE

Tel. : +90 282 685 44 80/81 Fax. : +90 282 685 42 09

\* Update and Issue: January 2020

\*\* Company reserves the right to make changes both on the documentation and products in order to improve them. Therefore, this brochure/catalog does not make a commitment for the technical specifications.

This data can not be used and reproduced without the permission of Termo Isi Sistemleri Ticaret ve Sanayi A.S.